



# Design Guidelines

Columbia, South Carolina

For questions regarding the restrictions in Woodcreek Farms, please contact the HOA Association Manager.



**Table of Contents**

Mission Statement..... 3  
Design Review Procedure ..... 5  
Architectural Design Standards..... 8  
Architectural Standard Details ..... 14  
Beaver Park Design Standards ..... 21  
The Crossing Design Standards ..... 22  
Clubridge B-5, Courtyard Villas, and Northwoods Villas Design Standards ..... 23  
Standard Fence Details - Enclosure of Entire Rear Yard..... 24  
Standard Fence Details - Pool Surrounds and Dog Pens ..... 30  
Standard Trash Enclosure Details ..... 33  
Landscape and Hardscape Guidelines ..... 35  
Fee Schedule ..... 43

For questions regarding the restrictions in Woodcreek Farms, please contact the HOA Association Manager.



## **Mission Statement**

The Architectural Control Committee (ACC) has responsibility for reviewing and approving all plans for alteration of any lot or improvement to be placed thereon before the lot is disturbed in any way. It is the goal of the ACC to maintain, within the overall community, pleasing aesthetic relationships of building to site and building to building, and not to restrict individual creativity or preferences. The ACC will use the design standards contained herein for the purpose of reviewing plans proposed for each lot but may consider the individual merits of each proposal due to special site consideration, architectural excellence, or otherwise. Unless otherwise approved by the ACC, homes shall be of harmonious design to the existing homes within the neighborhood it is being built.

The ACC shall be composed of HOA members who may or may not be members of the Board of Directors of Woodcreek Farms Homeowners Association. In addition, one or more architects, landscape architects, engineers, or other professional consultants, may serve the ACC and aid in their consideration.

New home construction in Woodcreek Farms is subject to stringent controls imposed by the ACC. Prior to lot clearing activity, the overall plan for construction must be approved in writing by the ACC.

Information required, as well as certain minimum details, are outlined in the following pages. Your request may be submitted by you or your representative to the office of Woodcreek Farms ACC at 1712 Woodcreek Farms Road. The review fee is due with your submission. Once submitted, the review fee is not refundable. The ACC generally meets every other week; however exact review dates can fluctuate based on number of submissions. Plans that do not meet the requirements of the architectural checklist will not be accepted or reviewed.

If changes are required, they will be noted on your plans. One set of plans along with a letter outlining any required changes will be returned to you. The second set of plans will be retained by the ACC to field verify the approved plans. Any required changes must be incorporated on the plans prior to resubmission.

If there are no changes required, the ACC will send an approval letter to the address on the application. Once received, you may then proceed with construction. The ACC will retain one copy of your plans to field verify that the approved plans are being followed.

If the approved plans need to be altered in any way, you must submit a plan for modification to the ACC for approval prior to making the changes in the field. Changes made during construction without approval from the ACC, will have to be torn out and reconstructed as per the approved plans.

NO ACTIVITY CAN COMMENCE WITHOUT WRITTEN APPROVAL FROM THE ACC. ACC approvals for new home construction are valid for a period of twelve months. All other ACC approvals are valid for a period of six months. The owner is responsible for contacting the ACC if the project is expected to extend longer than these periods. All ACC approvals are subject to final inspection at the cost of the homeowner.

For questions regarding the restrictions in Woodcreek Farms, please contact the HOA Association Manager.



Any alteration or improvement project started without written approval of the ACC is subject to fine. Refer to the Woodcreek Farms Homeowners' Association Fines Policy and Schedule of Fines.

These architectural guidelines regulate the following:

- New home construction
- Additions to existing homes
- Accessory Structures
- Pools
- Fences
- Patios, driveway extensions, and parking pads
- Revisions to already approved plans
- Recreational equipment
- Any other modification to the exterior of the home or property not listed here.
- Please refer to the Landscaping and Hardscape section of the Woodcreek Farms Design Guidelines for information regarding landscaping and hardscaping requirements.

If you are not sure whether you need something approved or not, please contact Woodcreek Farms HOA. The ACC and the Board of Directors reserve the right to amend these guidelines without notice.

For questions regarding the restrictions in Woodcreek Farms, please contact the HOA Association Manager.



## **Design Review Procedure**

### **Preliminary Residence and Site Plan Approval**

The preliminary review is not required but it is suggested that those building for the first time in Woodcreek Farms might avoid unnecessary delay and expense by having their plans reviewed to make sure they concur with the intent of the design guidelines.

### **Siting**

The ACC shall consider each site independently but shall give extensive consideration to each individual plan's impact upon adjacent home sites and view corridors and compatibility with existing structures. Care should be taken to locate each structure, whenever possible, so as not to infringe upon adjacent structures and home sites, view corridors and natural amenities of the area.

Consideration in this regard includes the following:

1. Topography of the site and surrounding home sites, common areas, golf course, and lakes.
2. Distant and intimate views from the home site.
3. Distant and intimate view of the home site from adjacent lots, common areas, and golf course.
4. Existing vegetation type and quality.
5. Existing water and drainage patterns.
6. Driveway access.
7. Height of proposed and adjacent structures.

### **Preliminary Review Drawings**

Preliminary Review Drawings shall contain all, or as many as deemed desirable, of the elements of the Final Review Drawings.

### **Miscellaneous Provisions**

All plans and other documents will be made in duplicate. Upon approval or rejection, one copy will be returned to applicant and the other copy will be retained by the ACC.

The ACC shall meet no less often than once a month and may, at its option, meet more often.

The first submittal for review shall be accompanied by the required design review fee.

ACC approvals for new home construction are valid for a period of twelve months. All other ACC approvals are valid for a period of six months. The owner is responsible for contacting the ACC if the project is expected to extend longer than these periods.

For questions regarding the restrictions in Woodcreek Farms, please contact the HOA Association Manager.



Upon approval by the ACC the Association will require the lot Owner to make a compliance deposit. The compliance deposit shall not exceed Ten Thousand (\$10,000) Dollars until otherwise changed by the Association. After completion of construction the ACC retains the right to inspect the construction, assign a value to each variance of the construction from the plans as approved, and either hold these funds until the variances have been corrected by the lot Owner or retain the funds without requiring correction of the variances. Any remaining funds shall be paid over to the lot Owner. Nothing herein shall be deemed to waive any other remedies of the Association or any lot Owner under the Declaration of CCRs or otherwise.

See "Request for Architectural Review" - Exhibit "A" for security deposit requirements.

### **Final Design Review**

The final design should incorporate all of the requirements of the Design Review Procedure and other portions of the Design Guidelines as well as comments from previous meetings and design reviews. Upon final agreement of the items required to be modified as indicated on the final submittal, all parties shall affix signatures on the actual plans attesting to the agreement. One set of documents will then be returned to the property owner marked "Approval for Construction", or "Resubmit." Only items requiring extensive modifications will necessitate re-submittal.

To insure compliance with all comments noted on the drawings during the ACC's preliminary and final reviews, no approval for clearing will be granted until the property owner or owner's agent has signed for and picked up the drawings from the HOA Management office.

### **Construction Rules**

1. In no event shall the Owner allow any grading or cutting of trees on the lot prior to approval of the proposed house location by the ACC.
2. All vehicles shall be parked at the lot to avoid damage to trees, paving, curbs, gutters, and any other improvements on the lot. Under no circumstances will there be parking on lots not under construction. There will be no parking on shoulders of roads. It is the builder's responsibility to see that subs adhere to these guidelines. All parking shall be limited to one side of the street to allow traffic to pass.
3. All stumps and brush are to be removed from the surface of the lot prior to foundation construction. Construction debris shall be removed as often as necessary to keep the lot and Structure thereon attractive. Construction debris shall not be dumped or buried in any area of the Community. Approved trash containers shall be placed on each lot during construction with all paper and other debris placed in said container to prevent it becoming blown or scattered on other property. A wire enclosure generally is an acceptable way of containing trash on the site.

For questions regarding the restrictions in Woodcreek Farms, please contact the HOA Association Manager.



4. It is the Builder's responsibility to grade lots in such a manner so as not to block any natural or man-made swales or drainage structures. Earth berms, hay bales, silt fence, mulch, boards, grassing, gravel blankets and any other approved siltation and erosion control measures shall be installed prior to grading of ALL lots to prevent mud and silt from running off the lot onto streets and any other adjoining property.
5. Downspouts are to be piped or directed to the front or rear of the lot. Immediate removal by the Builder is required of any mud or silt in the streets as a result of construction equipment, lack of silt control, or delivery of materials. (Crusher-run stone or other gravel is required at each access point of the lot where truck or construction traffic will be entering or exiting.) It is the responsibility of each Builder to keep the streets clean in front of the property on which he or she is building.
6. Confine building activity to the lot on which house is under construction. Landscaping shall be confined to building lot only. No trash, building material, landscape materials (rocks, etc.) or any other debris shall be placed on any adjacent or vacant lot. It is the responsibility of the Builder to protect any landscaping, equipment or structure on adjacent property and the builder shall also be responsible for the cost of repairs or replacement as required.
7. Silt fencing is to be installed to a depth of 6" where heavy runoff will likely occur or does occur.
8. Work by any construction personnel, sub-contractors, or suppliers (including deliveries, setup, or cleanup) within or adjacent to the construction site is permitted during the hours of 7am to 6pm (Monday through Friday) and 9am to 4pm (Saturday). No work shall be performed at any other times, including Sunday and holidays.
9. Trash and debris on site to be cleaned and removed daily. Upon completion of the residence, all construction materials to be removed and the jobsite to be cleaned of any trash or debris. All concrete trucks are to be washed out into concrete washout containers provided by the builder or taken back to the concrete plant.

### **Final Inspection**

The ACC will make a final inspection of the job site. The owner will be notified if there are any violations. If violations have occurred, the owner will be expected to correct the violations.

For questions regarding the restrictions in Woodcreek Farms, please contact the HOA Association Manager.



## **Architectural Design Standards**

1. **Square Footage** - From time to time the ACC shall establish a target square footage guideline for a section or group of lots, it being the intention of these guidelines to establish a range of pricing or cost of homes in a given area, with the ACC to have the right to vary square footage of homes in the case of innovative design or other amenities of the home which might bring it within the desired price range of homes within the area.

The ACC may allow sections of lots in which the square footage of homes may vary to a considerable degree in order to create a unique cluster or village type atmosphere; provided, the guidelines for any area or section of lots will be established prior to the sale of the first lot or lots within that particular area.

2. **Setbacks** - In no event shall the setbacks be less than those required by the City of Columbia Zoning Regulations. The ACC shall approve siting location prior to construction. Any request to the City of Columbia Zoning Authorities for alteration of setback lines MUST first be approved by the ACC PRIOR TO making a request for a variance. Various sections may have HOA regulated setbacks that are stricter than the City of Columbia setbacks.
3. **Garages** - Side entry garages are required where possible, with the ACC having the option to approve a front entry garage where a side entry is impractical or impossible, subject to certain guidelines such as a divider between the two doors if a two car garage. Single car garages and detached garages may be approved by the ACC where appropriate.
4. **Windows and Doors** - Anodized aluminum doors and windows, storm windows, screens, screen frames, and storm doors are not permitted. A prefinished aluminum may be used.
5. **Exterior Colors and Materials** - All exterior colors and materials of all Structures shall be submitted to the ACC for approval. An Owner wishing to make changes in these approved colors, may do so only with the further approval of the ACC in order to achieve a well-coordinated color scheme throughout the community. To be valid, approvals must be recorded with the HOA.

For questions regarding the restrictions in Woodcreek Farms, please contact the HOA Association Manager.





6. **Fireplace and Chimneys** - Fireplaces may be full masonry or with U.L. approved prefabricated, fire box and metal flue. Exterior of all chimneys, including gas log fireplaces, must be compatible with exterior masonry / stucco material used on front and foundations. Fireplace chimneys, if cantilevered, must extend down to grade or be included within wall lines of house. All chimneys are to have detailed top. Painted metal caps may be required to conceal circular prefabricated flue top.
7. **Gutters** – If gutters are to be used, owner shall indicate on the submitted plan the locations, style, and color.
8. **Roof** - Roofing materials and color shall be requested in the plans and specifications submitted to the ACC for approval. No plumbing or heating vent shall penetrate roof surfaces which face the street or streets adjacent to the lot. All plumbing or heating vents that penetrate the roof surface shall be painted to blend with the roof color.
9. **Driveways** - Driveways shall be constructed with concrete, provided however, that other hard surface materials such as brick, stamped, patterned, or colored concrete surfaces may be used if approved by the ACC. Specifications are to be submitted to the ACC for approval. Driveways are to be curved when possible taking into consideration existing trees and landscape plantings, and may include a paved turn-around area where possible. All driveways are to make a smooth transition to street with no abrupt elevation change.
10. **Landscaping** - Please refer to the Landscaping Guidelines for the standards, policies, and procedures for landscaping and landscaping review.
11. **Front Door Stoop and Steps** - All front door stoops and steps are to be brick, stone or tile topped; exposed concrete or stucco stoops and steps are NOT acceptable.
12. **Storm Doors** – Storm doors must match the architecture of the home, and be all glass with no screens.
13. **Trash Enclosures** – Where trash and recycling bins are stored in an area visible from the front or side streets, trash enclosures are required, and must be approved by the ACC. The enclosures shall compliment the architecture of the home and utilize the same building materials. (See examples in “Standard Trash Enclosure Details” section.) Trash and recycling bins can be concealed with natural screen planting. Refer to Landscaping Requirements item #10 of this document.
14. **Solar Panels** – Solar panels are not permitted.

For questions regarding the restrictions in Woodcreek Farms, please contact the HOA Association Manager.



## **House Designs, Colors and Material Guidelines**

- 1) Materials
  - a) A minimum number of exterior materials shall be used on Structures to avoid a cluttered appearance. Where more than one (1) material is used, one shall be dominant.
  - b) Secondary materials, when used, shall complement the dominant material in texture and color.
  - c) Recommended materials include:
    - 1) Siding: painted or stained wood, hardboard, or cement board beveled.
    - 2) Brick: samples of all brick and mortar must be submitted for approval.
    - 3) Cedar shakes, shingles or other simulated roofing; samples to be approved.
    - 4) Asphalt shingles which are black, shadow-black, grey, brown or weathered wood shingles are encouraged. Red and light colored roofs are not permitted. Cedar shake roofs are permitted.
    - 5) Painted or stained garage doors with recessed panels of simple design. Designer doors are encouraged.
    - 6) Hardcoat stucco system, no synthetic stucco. Stucco application method and/or Manufacturer's system to be submitted for approval.
    - 7) Natural stone and cultured stone.
  - d) Unacceptable materials include:
    - 1) Panelized artificial brick, panelized artificial stone, panelized artificial stucco panels, plywood siding, hardboard sheet siding, or vinyl siding.
    - 2) Unnatural tones of brick and stone.
    - 3) Any exposed poured concrete or concrete block walls are not permitted. These areas must be faced with brick, stone or stucco.
    - 4) Unpainted visible silver finish and aluminum flashing or finish on any material used on exterior of any side of house.
  - e) The exterior materials of all Structures on all lots shall be harmonious and complimentary
- 2) Colors
  - a) The exterior colors of the walls and roof of a single-family residential Structure shall be compatible and harmonious with the colors of nearby single-family residential Structures. No bright or reflective colors shall be allowed on main body of Structure. Cornice to match the window color.
  - b) A minimum number of exterior colors shall be used. When more than one color is used, one shall be clearly dominant.
  - c) Secondary colors shall be:
    - 1) Compatible with the dominant color
    - 2) Limited to architectural details such as fascia frames and other building trim.
  - d) High contrast colors, when used on Structures, shall be limited to smaller architectural elements such as entry doors. Entry door colors must be approved.

For questions regarding the restrictions in Woodcreek Farms, please contact the HOA Association Manager.



### **Screening Guidelines**

Screening shall be used within the Development to define private spaces or to attract or divert attention to or from particular views. Fences and walls are subject to the approval of the ACC, and shall follow the Standard Fence Details of the Woodcreek Farms Design Guidelines. Earth banks, berms, planting screens, natural no-clear areas, and all other screenings are subject to the approval of the ACC, and shall follow the Landscape Guidelines of the Woodcreek Farms Design Guidelines.

### **Recreation Equipment**

In order to avoid unsightly and aesthetically offensive structures, the location of tree houses, play structures, such as swing sets, gym sets and trampolines, basketball goals, pools, and spas must be approved by the ACC before construction or installation. All dwellings within the community, when seen from the curb facing the main entry door, shall exhibit a clean view of the entire front elevation unobstructed by these items. If deemed appropriate, landscaping or other approved screening may be required. In no event will play equipment be located any closer than twenty-five (25') feet from a rear property line for a lot backing on the golf course, lake, or public road. Satellite dishes shall be located such that they are not visible from the street. Screening is required to hide satellite dishes from street view.

### **Additions**

Additions to existing structures shall utilize the same type of construction as the structure to which they are attached. Exterior materials and finishes shall match. Prefabricated additions and structures are not allowed.

For questions regarding the restrictions in Woodcreek Farms, please contact the HOA Association Manager.



### **Accessory Structures**

Accessory structures not attached to the home shall follow the same standards as the primary structure, including but not limited to roof pitch, cornice, overhang, window and trim details, exterior façade, and finish material. ACC approval of structure and location is required. Prefabricated structures are not allowed.

### **Swimming Pools and Spas**

Swimming pools shall be in ground with a concrete or stone deck surround. Spa location and type must be approved by the ACC. Any swimming pool to be constructed upon any home lot must be approved by the ACC, with the final plans depicting any such improvement(s) in sufficient detail as to include all design components including materials, finishes and colors, additional landscaping, pool equipment, pool dimensions, exact location on the site, or any other requested element. No above ground pools, above ground spas, or hot tubs are permitted.

### **Generators**

The installation and use of any generators within the Development is subject to the review and prior written approval of the ACC. If approved, generators must be hidden from adjacent properties by means of an insulated enclosure facing the rear of the lot. Such location shall be located away from home air intakes and minimize any disturbance or noise to adjacent properties. Temporary generators must be stored in an approved indoor storage area that is not visible to adjacent properties. Temporary generators may only be used in the event of a temporary power outage such as caused by hurricanes, snow storms, ice storms, or other service interruptions. Temporary generator shall be returned to storage within one week of the restoration of power to the home. Temporary generators shall be located for use in an area away from home air intakes which minimizes any disturbance or noise to adjacent properties.

### **Exceptions**

Exceptions to these Architectural Design Standards may be allowed by majority vote of the members of the ACC, but only in cases where the ACC determines that (I) an exception is necessary in a particular case to avoid undue hardship or to deal with unique, unusual or extraordinary conditions, or circumstances encountered on a particular lot; and (II) the exception will serve the spirit of these Architectural Design Standards and not be, in the opinion of the ACC, a detriment to the Development. Such exceptions shall be in writing. No exception allowed hereunder shall establish any precedent or other effect upon any other situation in which an exception is requested of, or considered by, the ACC. Approval of any Structure by the ACC is limited to the esthetics of style, color, material, texture, and general streetscape appearance and therefore in no way is a certification that the Structure has been built in accordance with any governmental rule or regulation, or that the Structure complies with sound building practice or design. Proper location on a specific lot of the Structure, or any appurtenances (fences, pools, etc.) with regard to setbacks, easements, or any other restriction is the sole responsibility of the Builder and/or Owner.

For questions regarding the restrictions in Woodcreek Farms, please contact the HOA Association Manager.



No member of the ACC, its architect, agent or employees shall be liable for damages to any owner of property affected by this declaration by reason of mistake in judgment, negligence, or nonfeasance arising out of or in connection with the approval or disapproval or failure to approve or disapproved any such plans or specification. Further, any permission granted for construction by the ACC shall not constitute or be construed as an approval, warranty or guaranty, expressed or implied, by the ACC, its architect, agents or employees of the structural stability, design or quality of any building or other improvement or of the contractor who constructs such buildings or other improvements. Every person, or entity, who submits plans or specifications to the ACC for approval agrees, by the submission of such plans and specifications, and every owner of any lot agrees, that he will not bring any action or suit against any member of the ACC, to recover for any such damages.

#### **Amendments**

These Architectural Design Standards may be amended from time to time by a majority vote of the ACC upon final approval by the Board of Directors.

#### **Builder Requirements**

Builders for new home construction shall be required to hold a current LLR South Carolina Residential Builders Commission home builder license and a current license issued by the City of Columbia.

The requirements established by the ACC are solely for its benefits and are not to be construed to benefit any owner or any party whatsoever. Owner is solely responsible for the selection of a builder or construction manager. The ACC shall not be held liable for any injury, damages, or loss arising out of the manner or quality of any construction on the owner's property.

For questions regarding the restrictions in Woodcreek Farms, please contact the HOA Association Manager.



## Architectural Standard Details

LOT #

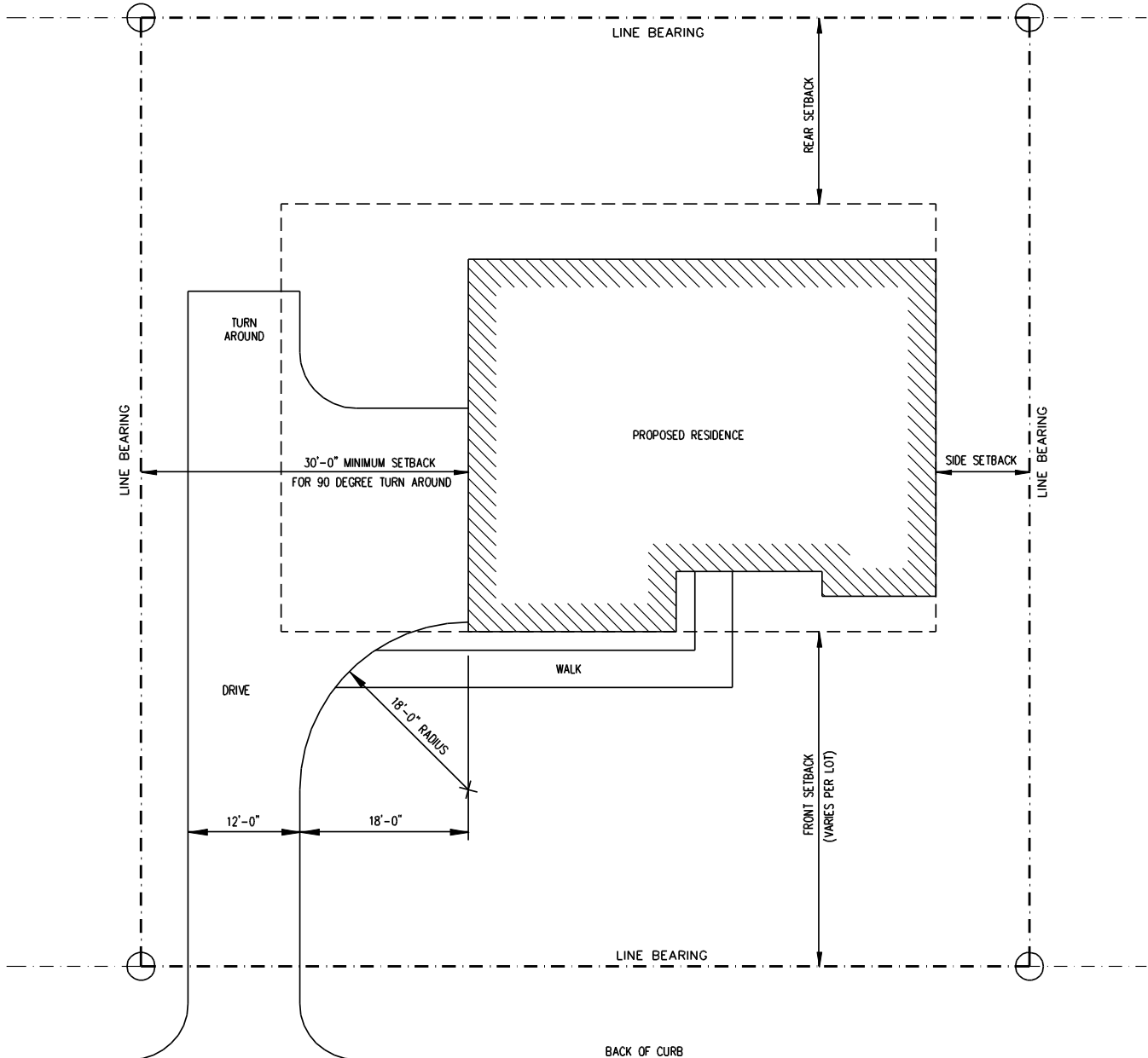

STREET NAME

## TYPICAL SITE PLAN

For questions regarding the restrictions in Woodcreek Farms, please contact the HOA Association Manager.

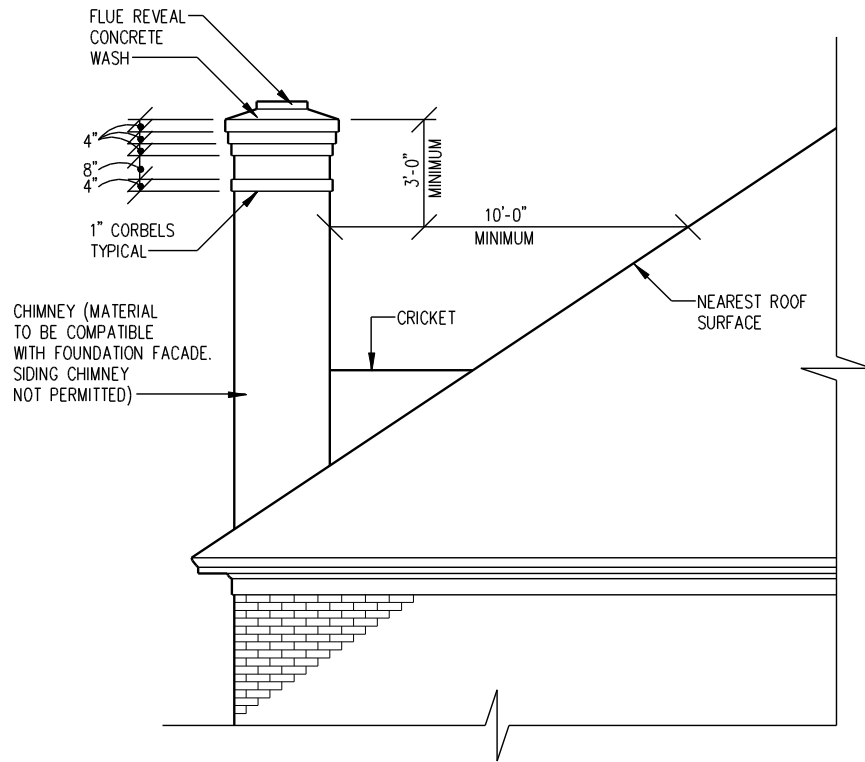

**TYPICAL CHIMNEY DETAIL**

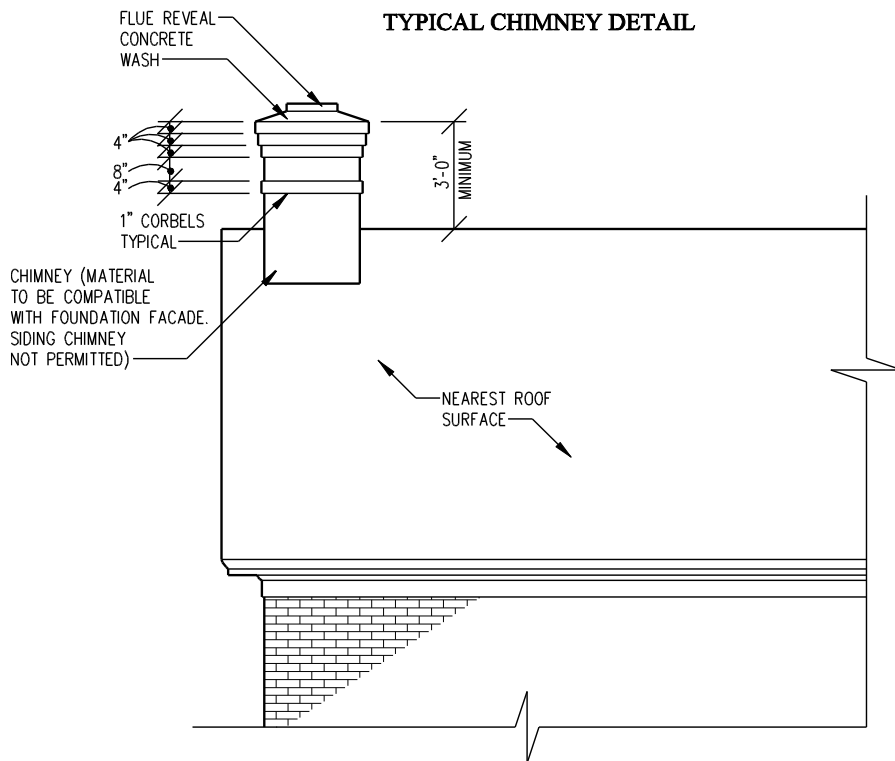

**TYPICAL CHIMNEY DETAIL**

For questions regarding the restrictions in Woodcreek Farms, please contact the HOA Association Manager.

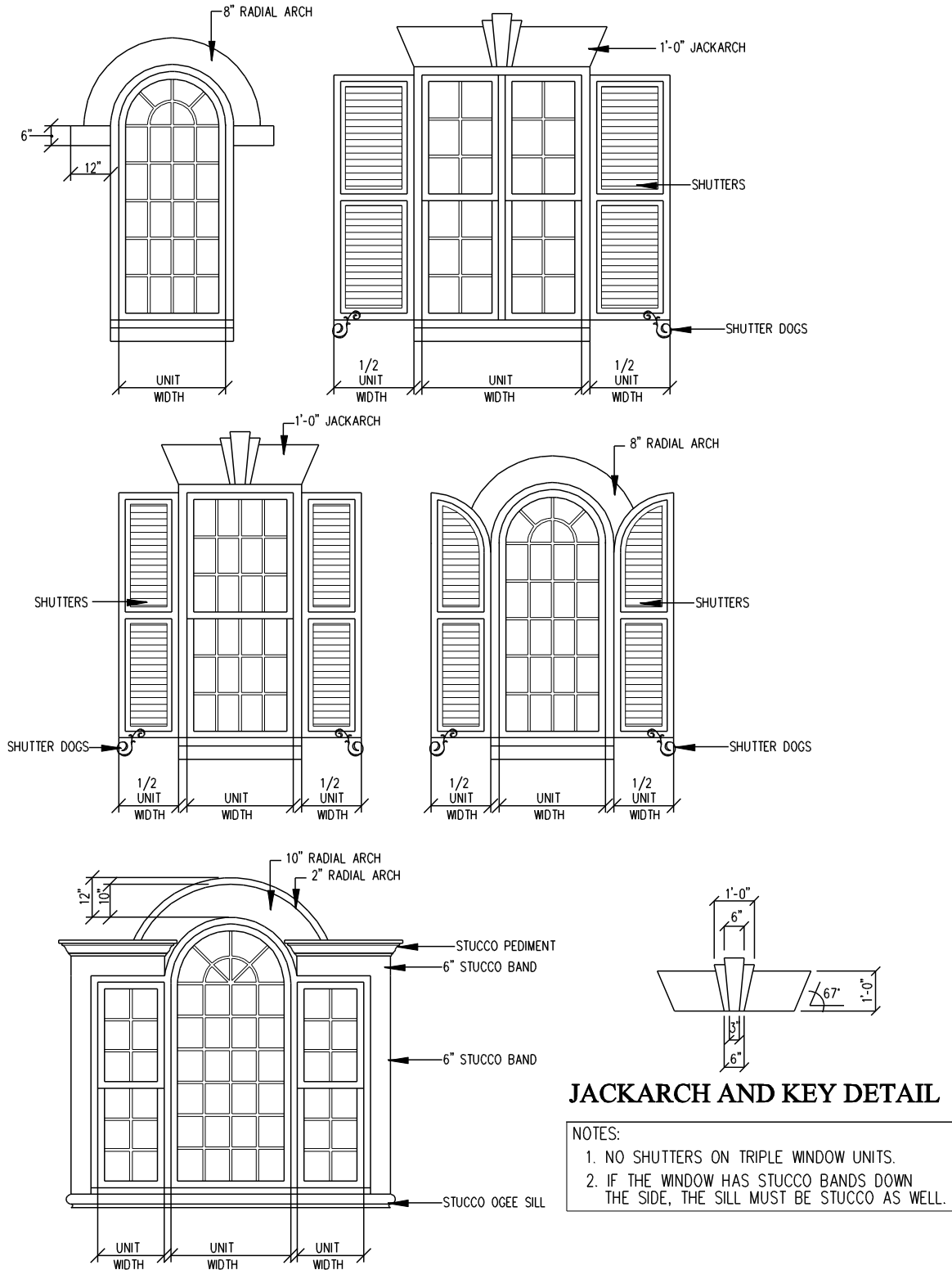

**NOTES:**

1. NO SHUTTERS ON TRIPLE WINDOW UNITS.
2. IF THE WINDOW HAS STUCCO BANDS DOWN THE SIDE, THE SILL MUST BE STUCCO AS WELL.

**WINDOW DETAILS**

For questions regarding the restrictions in Woodcreek Farms, please contact the HOA Association Manager.



NOTE: BELT BAND TO WRAP ENTIRE HOUSE.

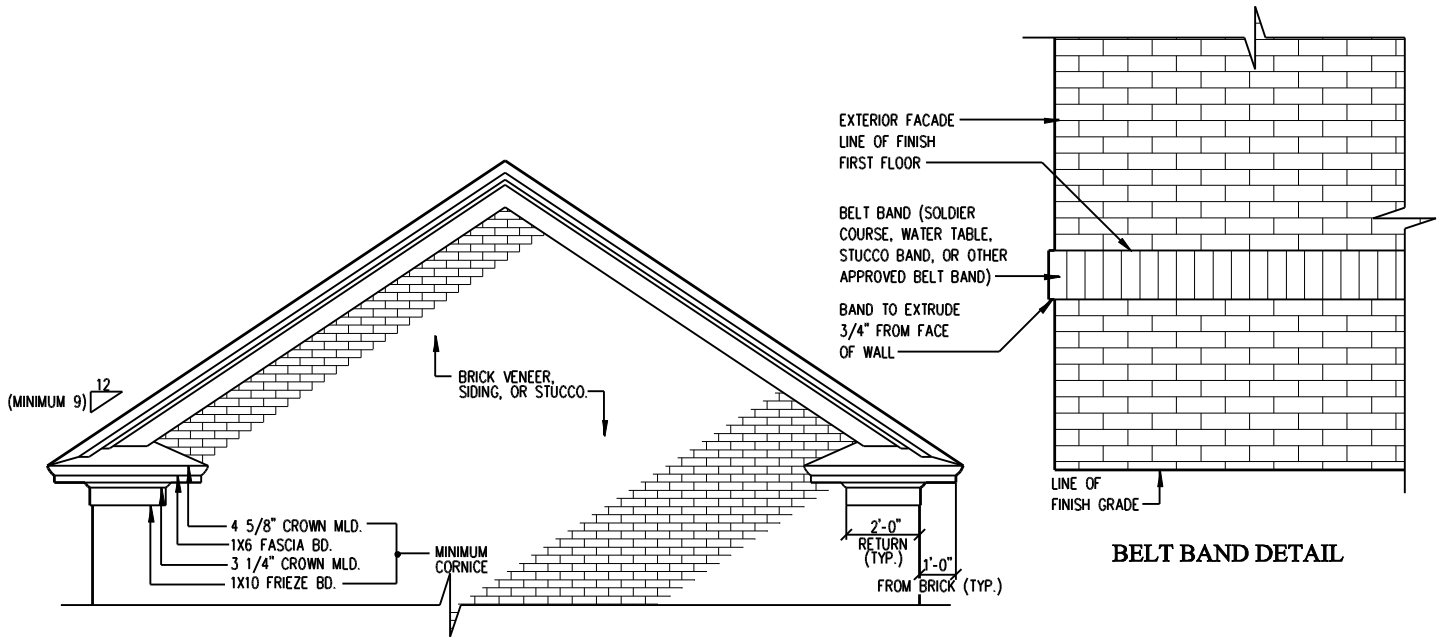

**DETAIL AT GABLE ROOF  
(PITCH, CORNICE, OVERHANG, ETC.)**

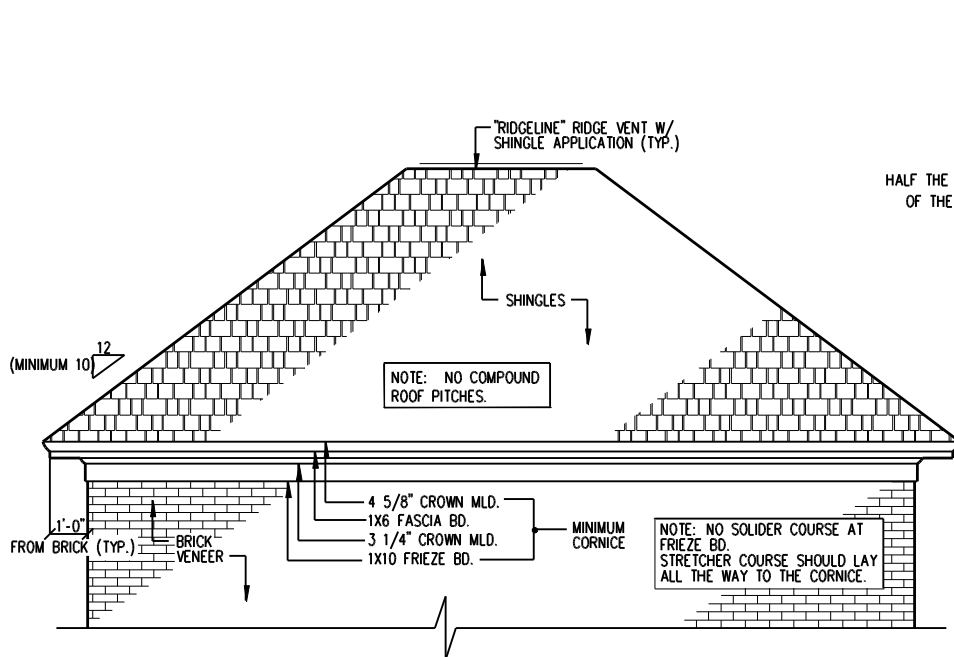

**DETAIL AT HIP ROOF  
(PITCH, CORNICE, OVERHANG, ETC.)**

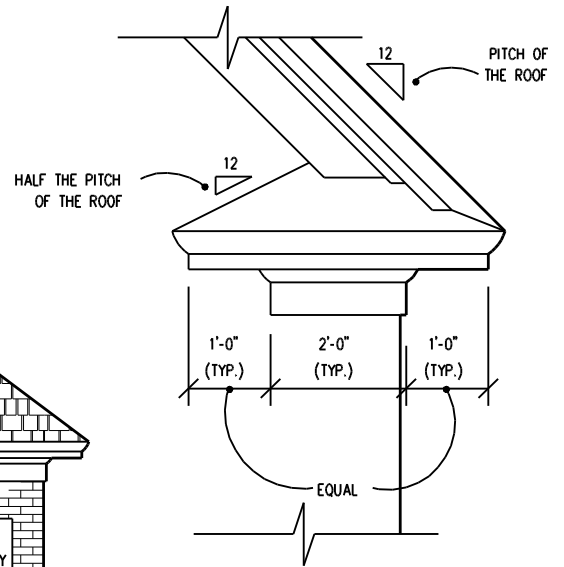

**TYPICAL RETURN DETAIL**

For questions regarding the restrictions in Woodcreek Farms, please contact the HOA Association Manager.

COLUMN DIAMETERS SHOULD BE PROPORTIONAL TO THEIR HEIGHT. THE DIAMETER SHOULD BE SPECIFIED ON THE PLANS. THE ARB SHALL DETERMINE APPROPRIATE DIAMETERS.

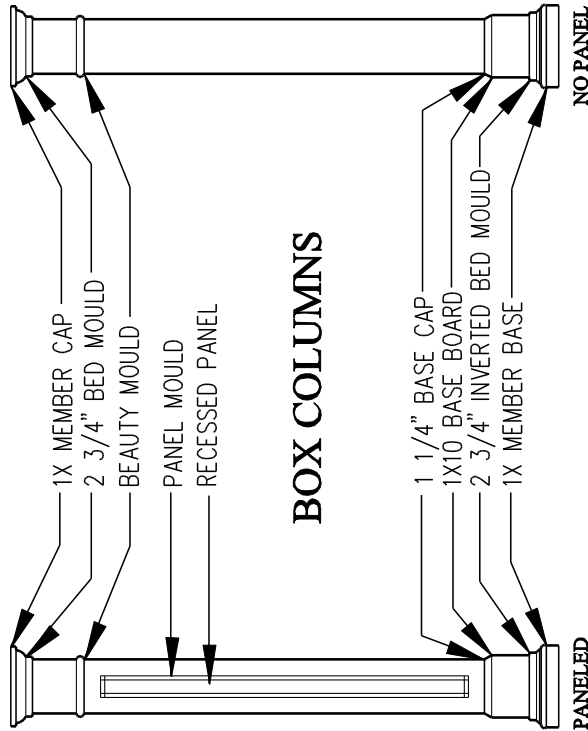
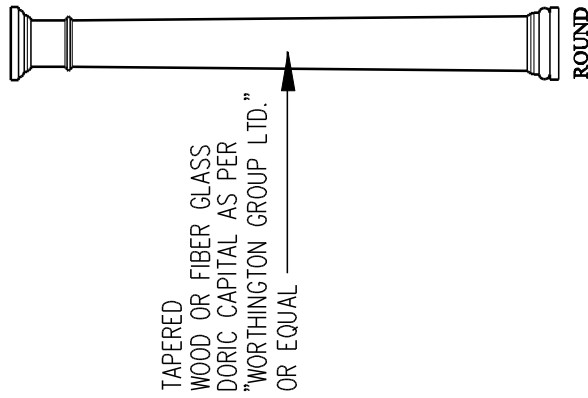

**COLUMN DETAILS**

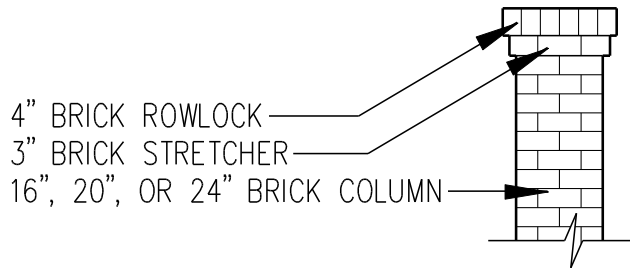

**TYPICAL BRICK COLUMN**

For questions regarding the restrictions in Woodcreek Farms, please contact the HOA Association Manager.

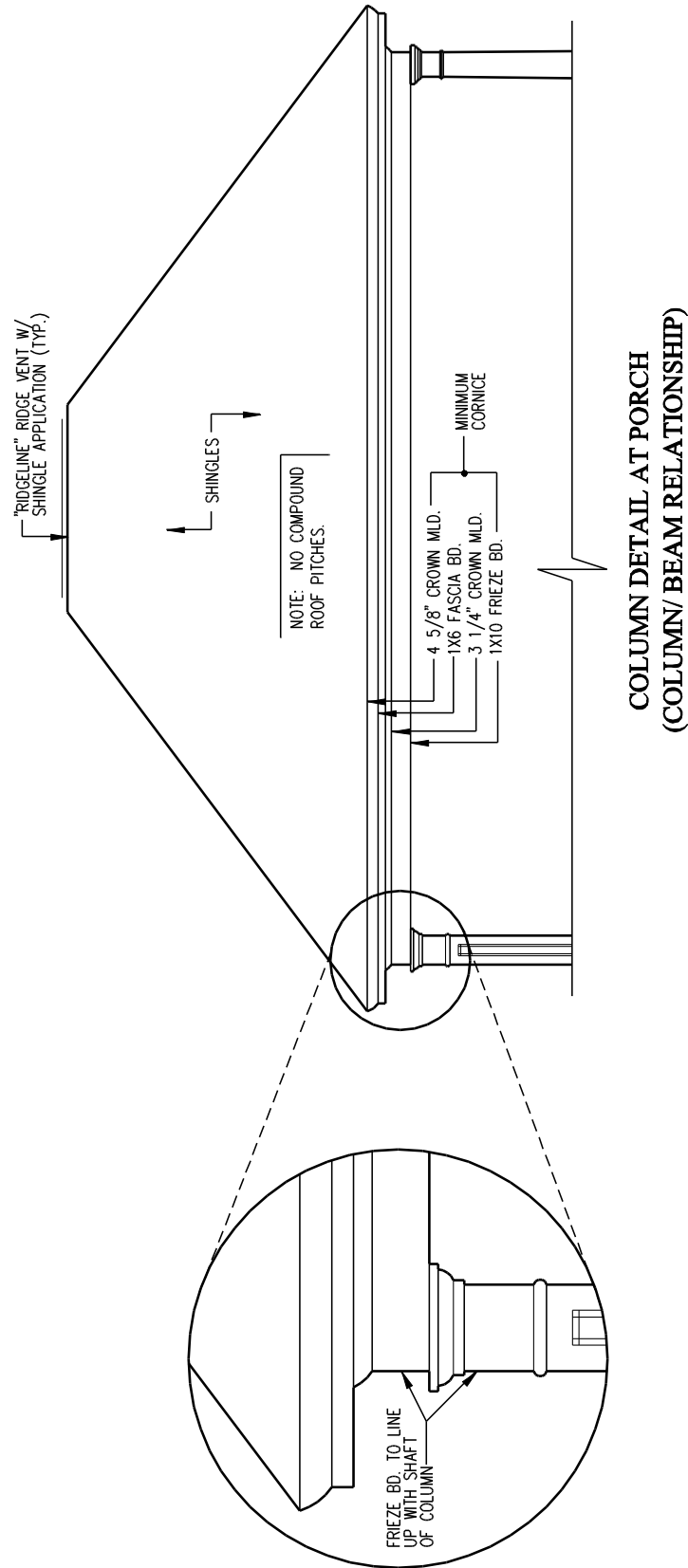

For questions regarding the restrictions in Woodcreek Farms, please contact the HOA Association Manager.

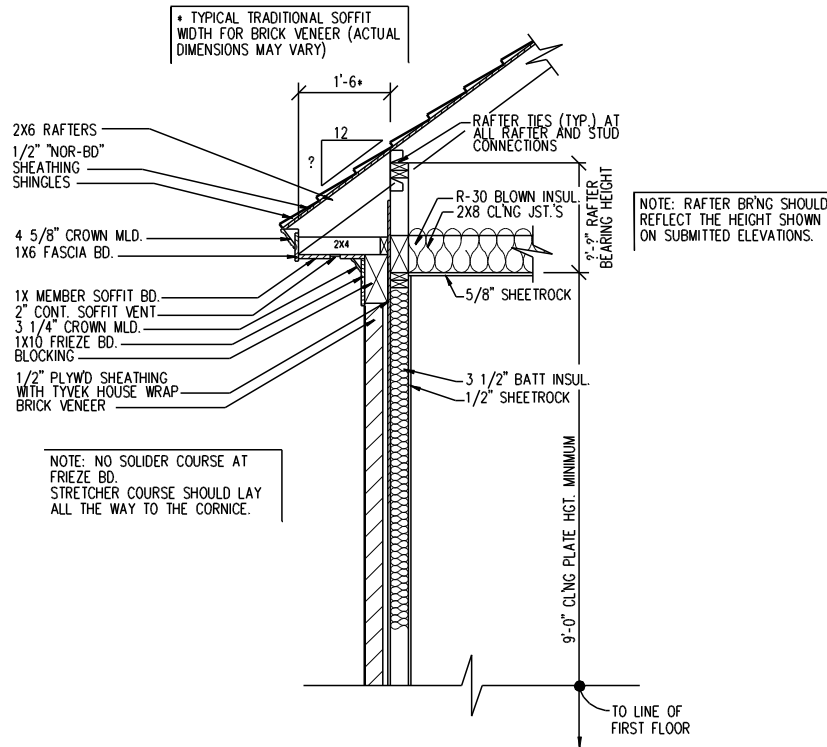

**INFORMATION NEEDED ON BRICK WALL SECTION TYPICAL**

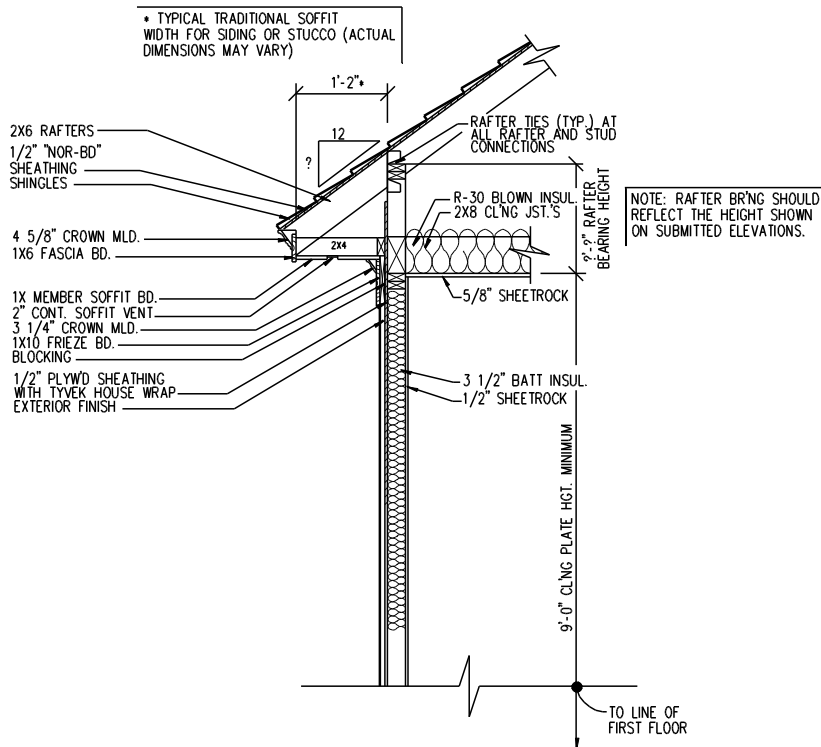

**INFORMATION NEEDED ON STUCCO OR SIDING WALL SECTION TYPICAL**

For questions regarding the restrictions in Woodcreek Farms, please contact the HOA Association Manager.



## **Beaver Park Design Standards**

Beaver Park is a gated, zero lot line section of Woodcreek Farms. Beaver Park is subject to all the architectural and landscaping standards as the rest of Woodcreek Farms. In addition, Beaver Park has the following mandatory enhanced standards:

- Minimum 10 ft. ceiling height on first floor, and 9 ft. ceiling height on second floor
- All units will have brick and wrought iron accent walls at front property line. Project brick and mortar to match existing brick accents as closely as possible.
- Brick privacy walls at rear lot line with wrought iron gate, at all interior lots
- Brick column and arched wrought iron accent walls at rear lot line, at all lake lots
- Brick privacy wall from zero lot line side of home to rear wall (Privacy wall to be constructed of same brick as home)
- True operable shutters will be required where installed
- Sidewalks at street with "picture frame" detail will be required
- Driveway accents of brick pavers or "picture frame" detail will be required
- Simulated divided light (SDL) windows (SDL windows have permanent grilles on the interior and exterior of the glass and a spacer bar between the glass)
- Minimum heated square footage shall be 2,500 sq. ft. on the interior lots and 3,000 sq. ft. on lakeside lots
- Copper returns at cornice
- 9' wide single doors on garage with Designer Panels and Hardware

For questions regarding the restrictions in Woodcreek Farms, please contact the HOA Association Manager.



## **The Crossing Design Standards**

The Crossing is a unique section of Woodcreek Farms. The Crossing is subject to all the architectural and landscaping standards as the rest of Woodcreek Farms, with the following modifications:

- Vinyl/aluminum wrapped cornice is permitted with a 1x2 shingle mould and 1x2 trim board on a 1x8 frieze board. Gutters are encouraged and may substitute the 1x2 shingle mould in areas used.
- Box returns are permitted on sides and rear. Shingled returns are required on street elevations, and shall follow the detail in the Design Guidelines.
- Compound roof pitches are allowed with a maximum of a two pitch difference.
- Garages must be side load. Additional garage bays that face the street shall be considered if they are set back from the main body of the house and located behind the main garage.
- Foundations shall be crawlspace or raised slab where the finished floor line is a minimum 20" above finish grade.
- Soldier courses or belt bands shall be located at the first floor line on all street elevations.
- Shed roofs over porches are encouraged to have standing seam metal roofs.
- Prefabricated outbuildings are not permitted.

For questions regarding the restrictions in Woodcreek Farms, please contact the HOA Association Manager.



## **Clubridge B-5, Courtyard Villas, and Northwoods Villas Design Standards**

These neighborhoods are subject to all the architectural and landscaping standards as the rest of Woodcreek Farms, with the following modifications:

- Vinyl/aluminum wrapped cornice is permitted with a 1x2 shingle mould and 1x2 trim board on a 1x8 frieze board. Gutters are encouraged and may substitute the 1x2 shingle mould in areas used.
- Box returns are permitted. Shingled returns are encouraged on street elevations. Where shingled returns are used, they shall follow the detail in the Design Guidelines.
- Compound roof pitches are allowed with a maximum of a two pitch difference.
- Front load, rear load, and side load garages are permitted, and are recommended to set back from the main body of the house 2'-0" or more. Designer garage doors are recommended.
- Slab on grade construction is permitted. Raised slab construction is recommended.
- Vinyl siding is permitted as a secondary material (E.g. In end-gables)
- All fences must have 4'-0" minimum width gates. The fence rails must be raised 4" off finish grade, and mulch or pine straw must be installed around fence to prevent damage during yard maintenance.
- Shed roofs over porches are encouraged to have standing seam metal roofs.
- No detached structures are allowed in these three neighborhoods.
- Landscaping beds provided by the builder enable ease/speed of mowing. Additional landscaping beds or bed extensions are not allowed. Sodded areas are to be clear of all yard or personal items (i.e. bird feeders, bird baths, furniture, recreational equipment, satellite dishes, etc.)
- These neighborhoods are subject to unique landscape standards. See Landscape and Hardscape Guidelines for details.

### **Clubridge B-5 Phase 1**

- Homes must utilize the same plans as the existing homes in Clubridge B-5 Phase 1, or have a design with similar characteristics and exterior finish materials.
- Homes on Clubridge Road are required to have the same accent fencing style as the existing homes on Clubridge Road.

For questions regarding the restrictions in Woodcreek Farms, please contact the HOA Association Manager.



## **Standard Fence Details - Enclosure of Entire Rear Yard**

### Requirements:

1. This section applies to fences that enclose more than 75% of the rear yard.
2. Owner to select only **one** of the fences shown. A plat denoting the placement of the fence shall be submitted to the ACC for approval.
3. The height of the fence shall be per the detail selected.
4. All wood fencing to be double-faced, either cedar or treated wood - stained or painted. Submit stain or paint color to ACC.
5. 16" x 16" columns with two corbels shall be positioned on the lot corners. Intermittent columns may also be required. Column spacing shall be determined by the ACC. The façade of the columns shall match the home. (IE. Stucco or Brick)
6. All gate(s) shall be compatible to that of the fence.
7. Landscaping will be required on the exterior portion of the fence when visible from the street, lake, or golf course. The landscaping plan shall be submitted for architectural review at the same time that the fence plan is submitted. The variety and size of plant materials needs to be included. All landscaping shall be installed within 45 days from the construction of the fence.
8. Owner accepts all responsibility of landscaping and perpetual maintenance of the fence and landscaping.
9. Fences should be set back 40' from the golf course and lakes.
10. Chain link and vinyl fencing are not permitted.

For questions regarding the restrictions in Woodcreek Farms, please contact the HOA Association Manager.



## Standard Fence Details - Enclosure of Entire Rear Yard

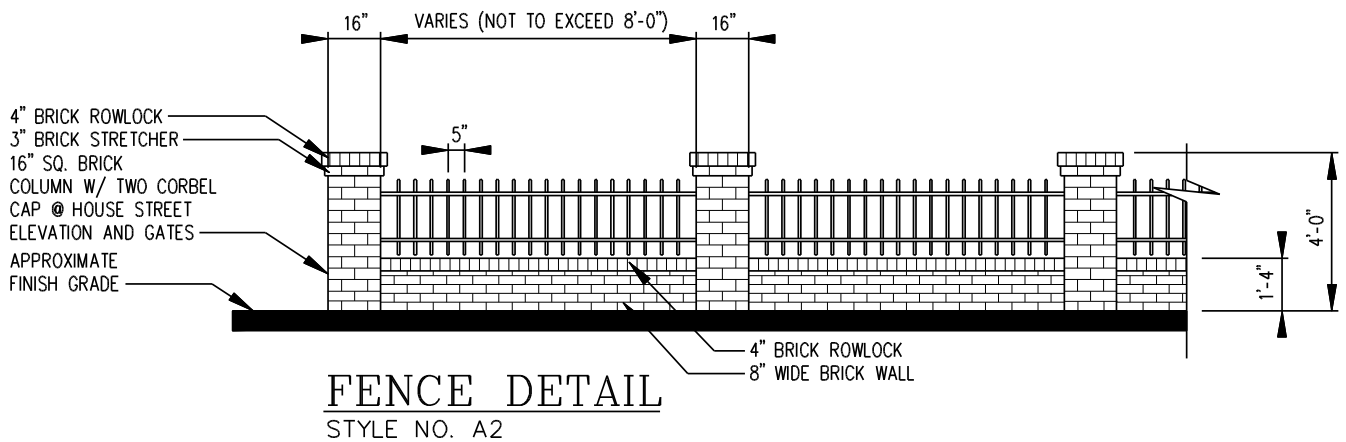
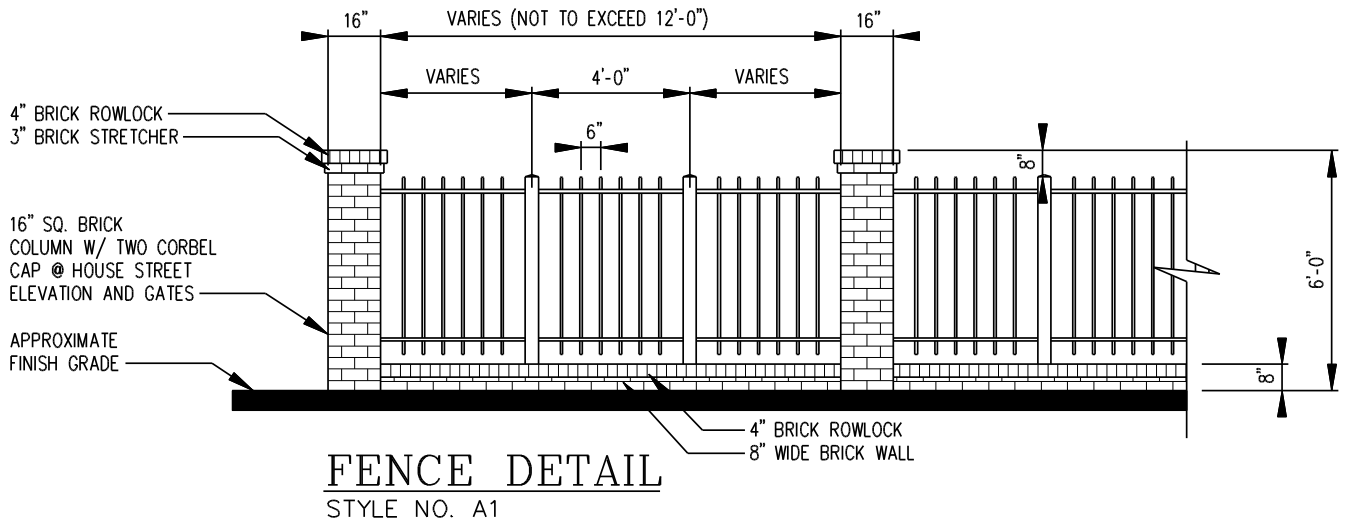

For questions regarding the restrictions in Woodcreek Farms, please contact the HOA Association Manager.

## Standard Fence Details - Enclosure of Entire Rear Yard

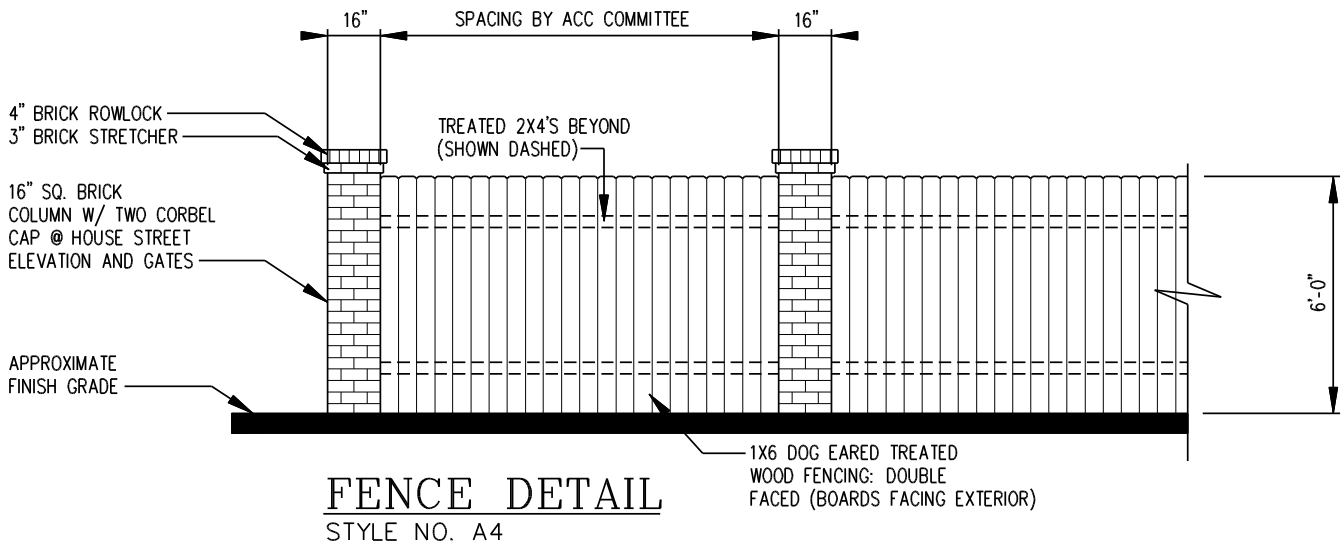
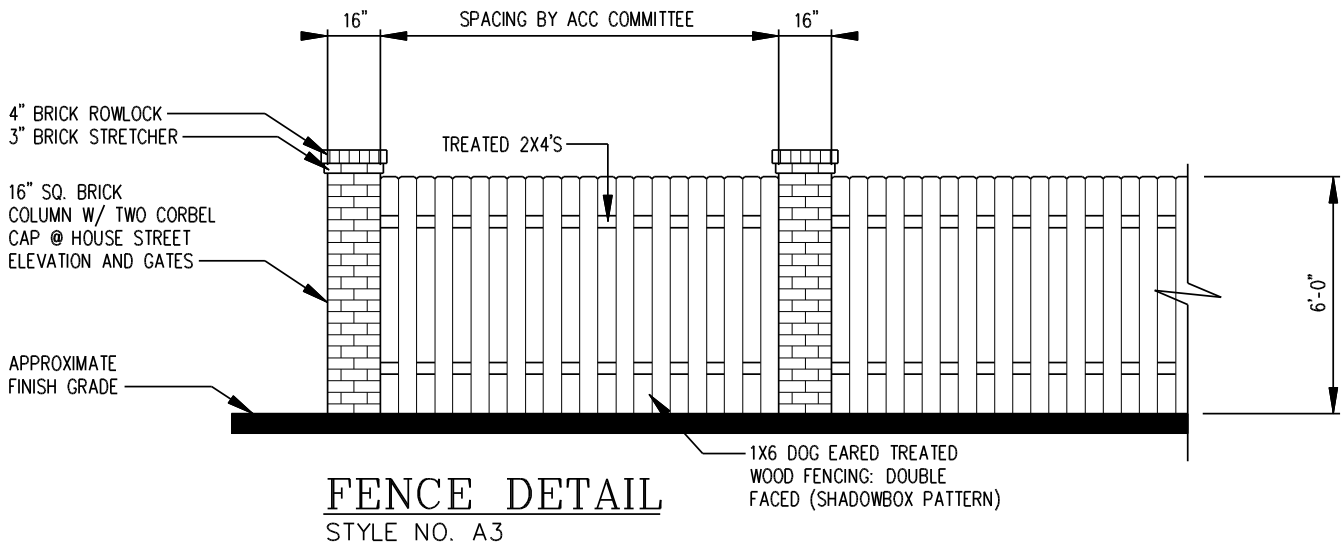

For questions regarding the restrictions in Woodcreek Farms, please contact the HOA Association Manager.

## Standard Fence Details - Enclosure of Entire Rear Yard

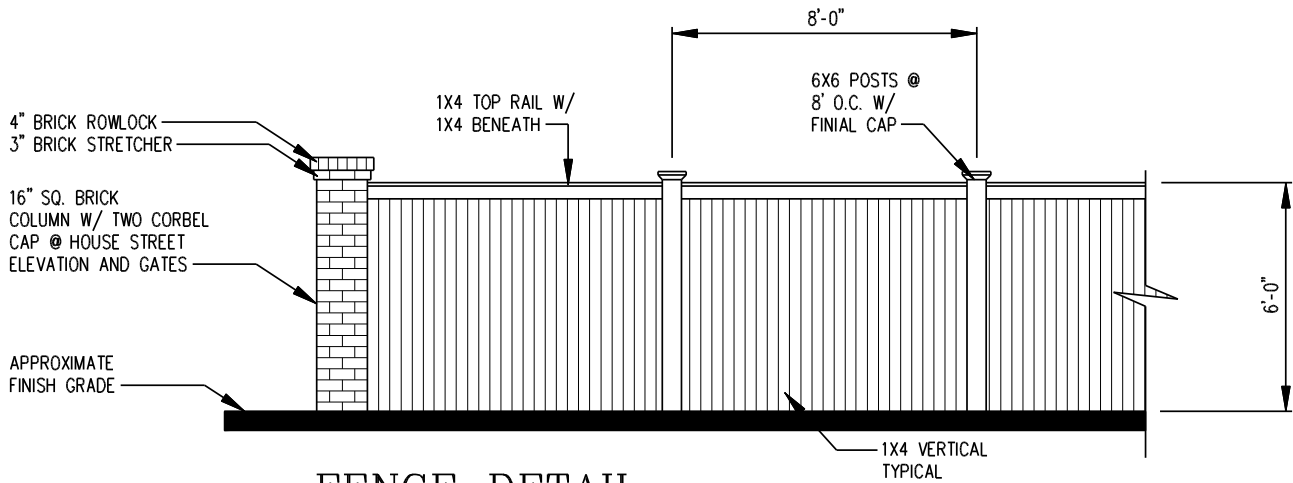

**FENCE DETAIL**  
STYLE NO. A5

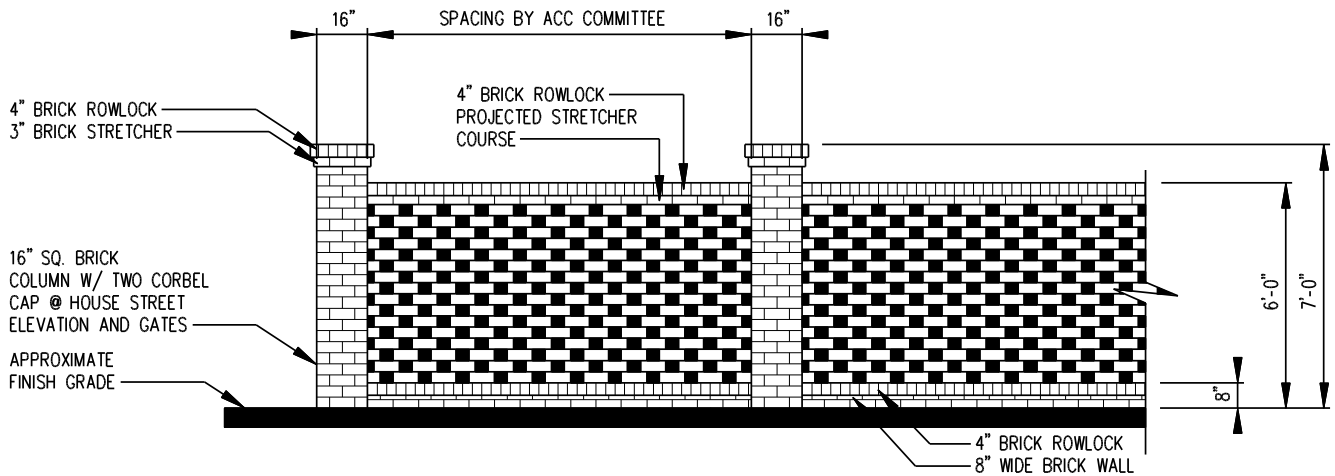

**PEIRCED BRICK WALL DETAIL**  
STYLE NO. A6

For questions regarding the restrictions in Woodcreek Farms, please contact the HOA Association Manager.

**Standard Fence Details - Enclosure of Entire Rear Yard**

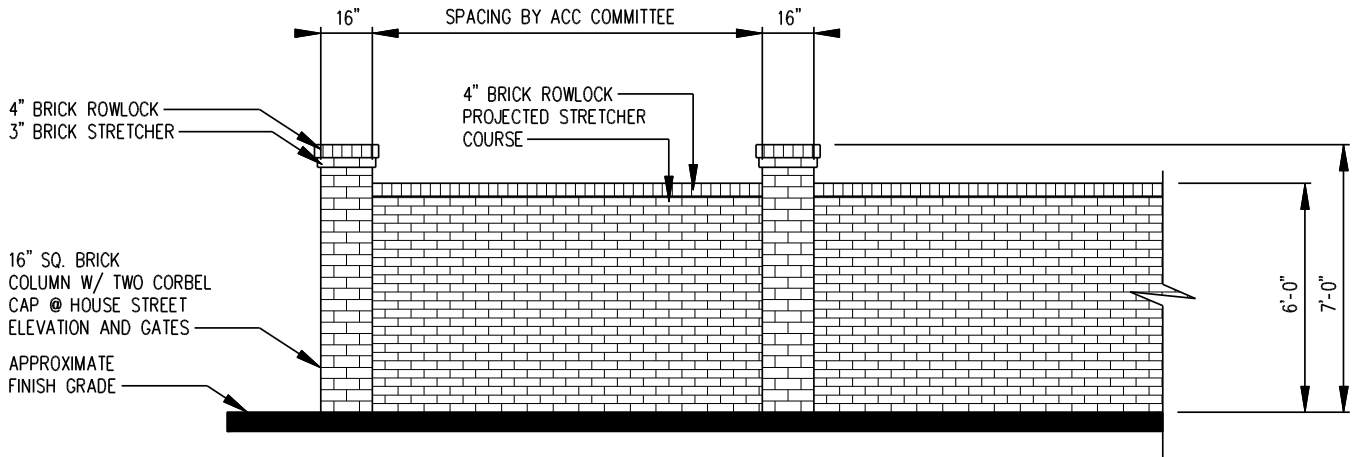

**BRICK PRIVACY WALL DETAIL**  
STYLE NO. A7

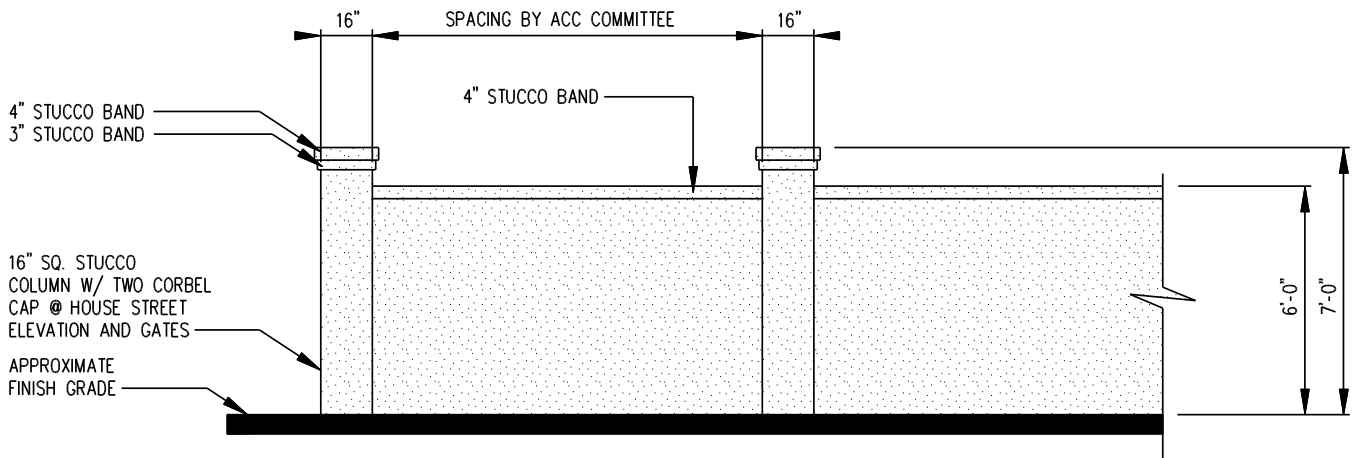

**STUCCO PRIVACY WALL DETAIL**  
STYLE NO. A8

For questions regarding the restrictions in Woodcreek Farms, please contact the HOA Association Manager.

**Standard Fence Details - Enclosure of Entire Rear Yard**

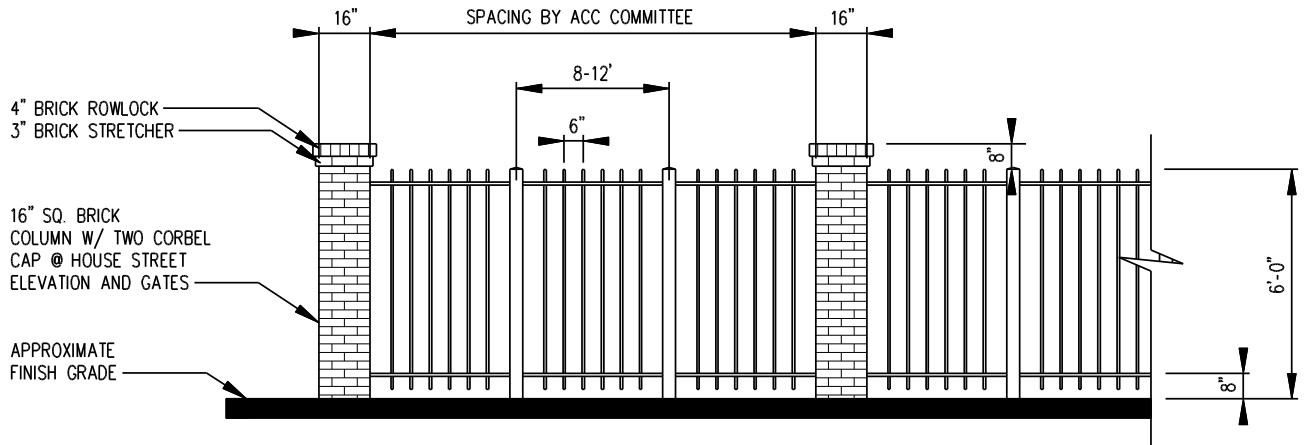

**FENCE DETAIL**  
 STYLE NO. A9

For questions regarding the restrictions in Woodcreek Farms, please contact the HOA Association Manager.



## **Standard Fence Details - Pool Surrounds and Dog Pens**

### Requirements:

1. This section applies to fences that enclose pool areas or dog pens, and may not be used to enclose the entire back yard.
2. Owner to select only **one** of the fences shown. A plat denoting the placement of the fence shall be submitted to the ACC for approval.
3. The height of the fence to be **4'**.
4. All wood fencing to be double-faced, either cedar or treated wood – stained or painted. Submit stain or paint color to ACC.
5. 16" x 16" columns with two corbels may be required by ACC.
6. All gate(s) shall be compatible to that of the fence.
7. Landscaping will be required on the exterior portion of the fence when visible from the street, lake, or golf course. The landscaping plan shall be submitted for architectural review at the same time that the fence plan is submitted. The variety and size of plant materials needs to be included. All landscaping shall be installed within 45 days from the construction of the fence.
8. Owner accepts all responsibility of landscaping and perpetual maintenance of the fence and landscaping.
9. Fences should be set back 40' from the golf course and lakes.
10. Chain link and vinyl fencing are not permitted.
11. Owner shall be responsible for ensuring fences that enclose pools meet any requirements from the governing zoning ordinance.

For questions regarding the restrictions in Woodcreek Farms, please contact the HOA Association Manager.

## Standard Fence Details - Pool Surrounds and Dog Pens

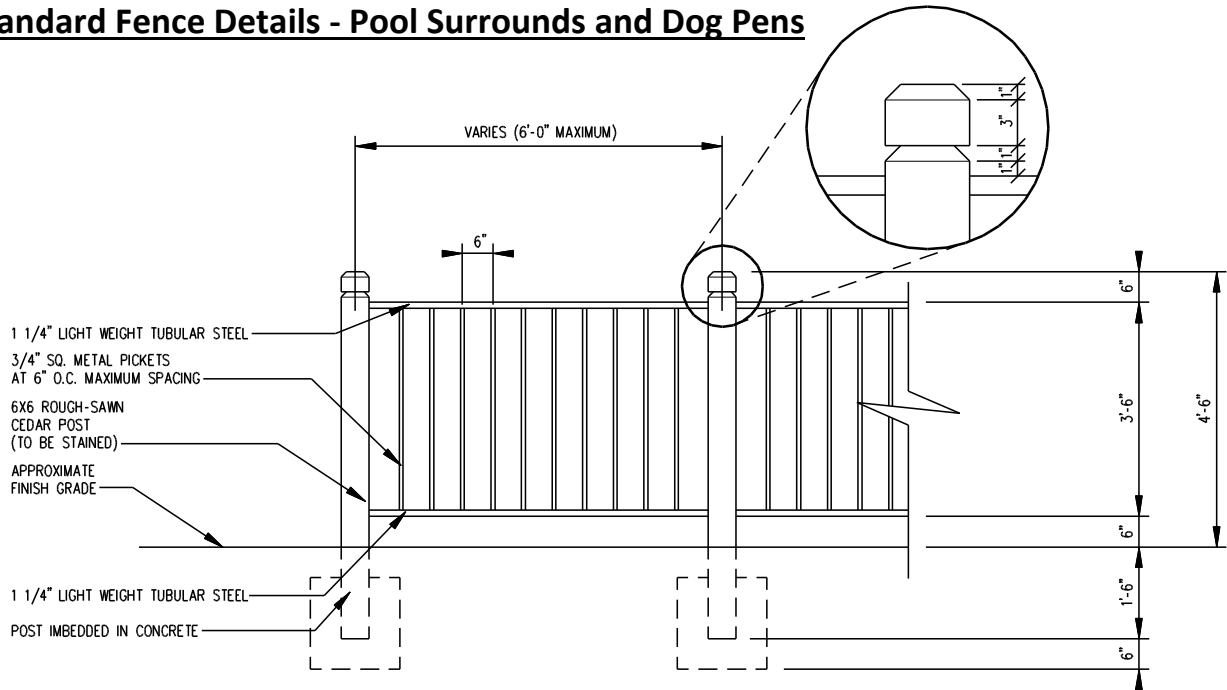

FENCE DETAIL  
STYLE NO. B1

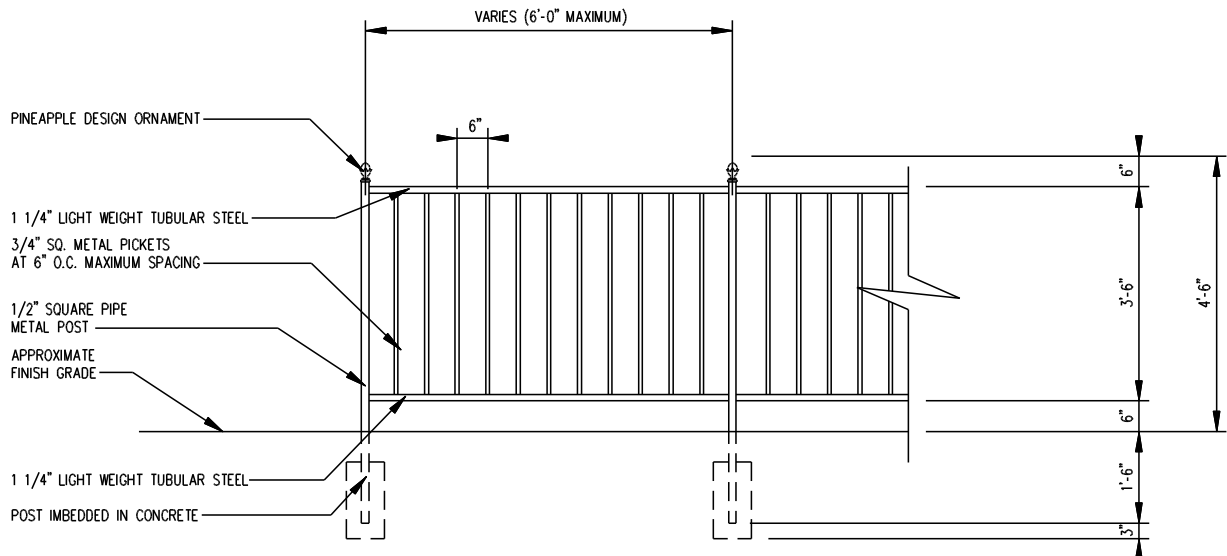

FENCE DETAIL  
STYLE NO. B2

For questions regarding the restrictions in Woodcreek Farms, please contact the HOA Association Manager.

## Standard Fence Details - Pool Surrounds and Dog Pens

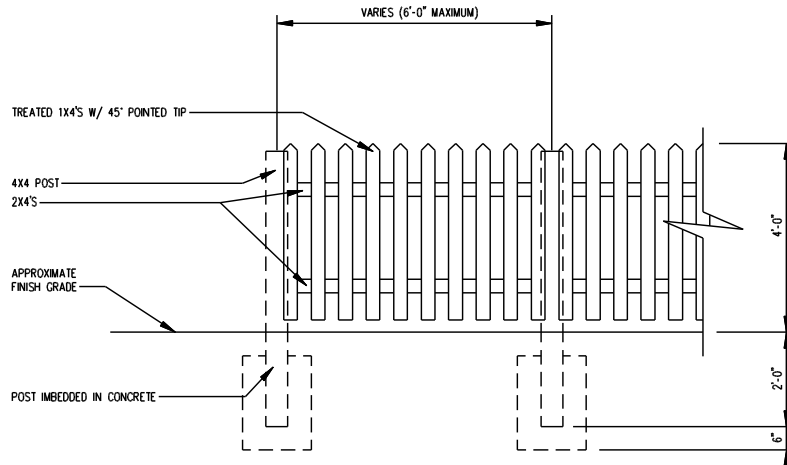

**FENCE DETAIL**  
STYLE NO. B3

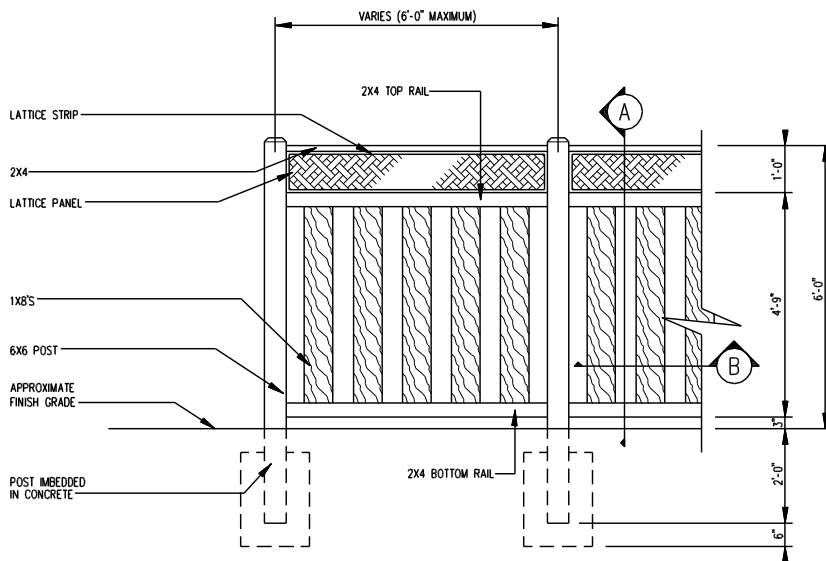

**FENCE DETAIL**  
STYLE NO. B4

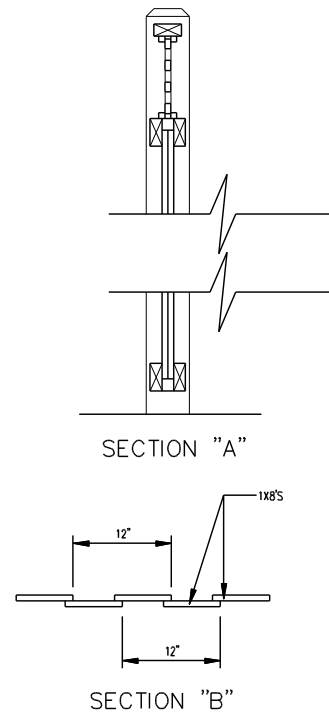

For questions regarding the restrictions in Woodcreek Farms, please contact the HOA Association Manager.



**Standard Trash Enclosure Details**

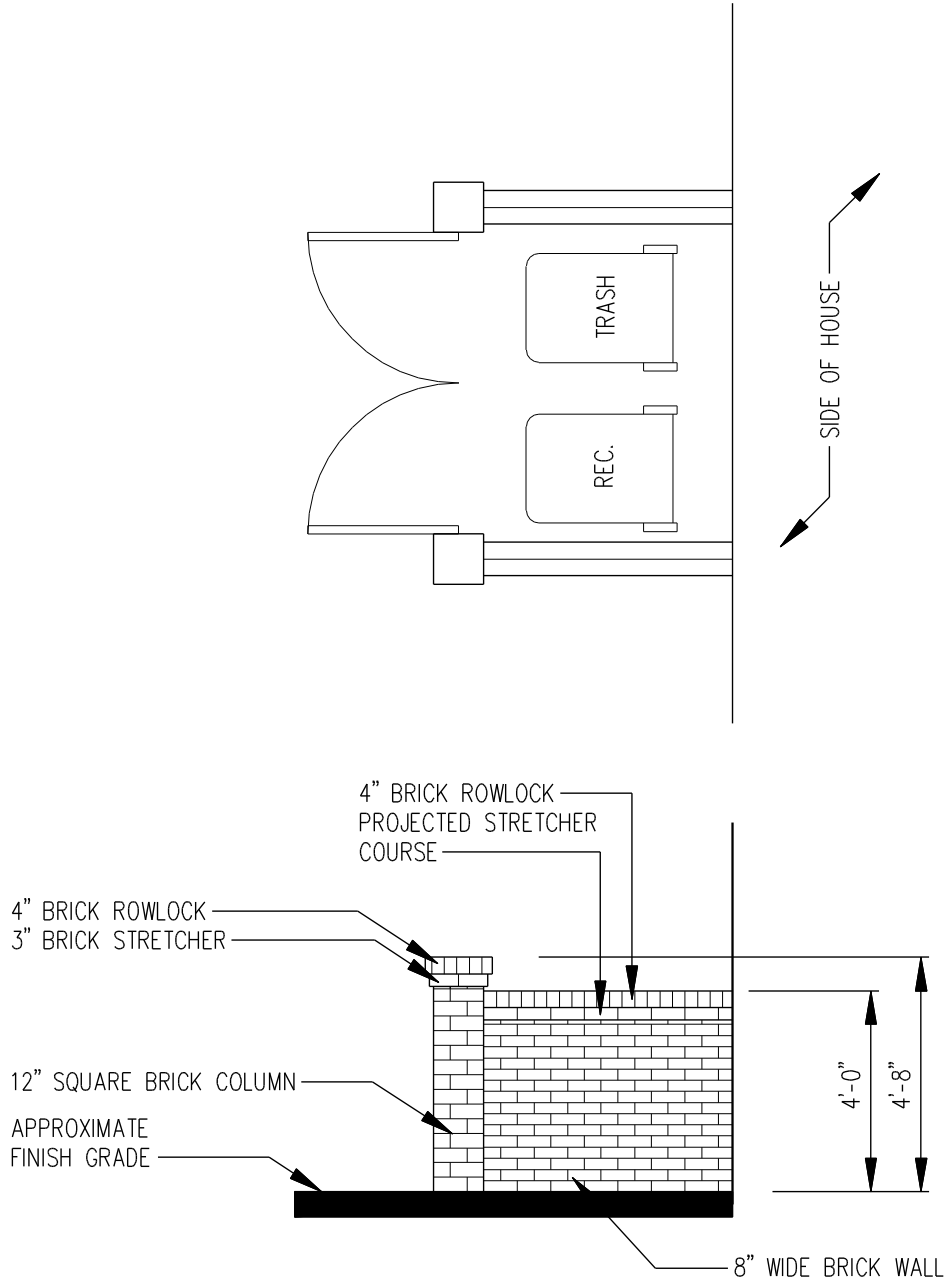

**BRICK TRASH ENCLOSURE  
(STREET ELEVATION)**

For questions regarding the restrictions in Woodcreek Farms, please contact the HOA Association Manager.

**Standard Trash Enclosure Details**

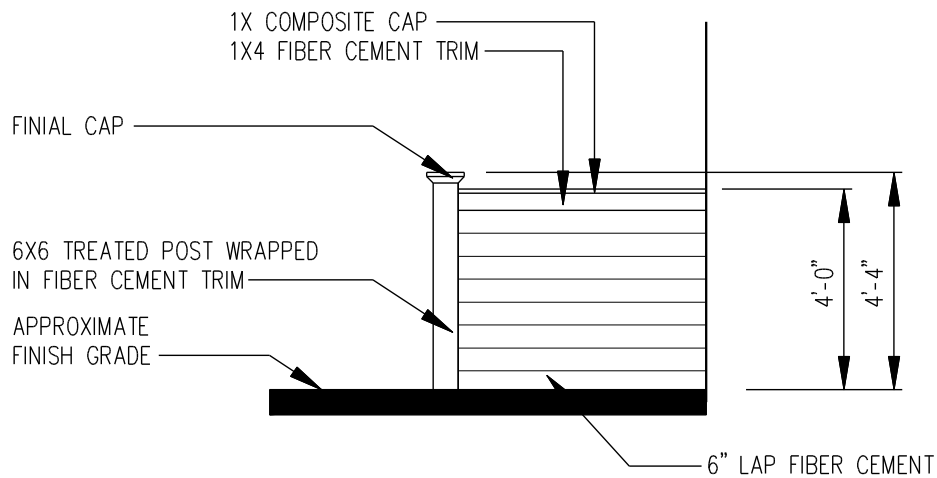
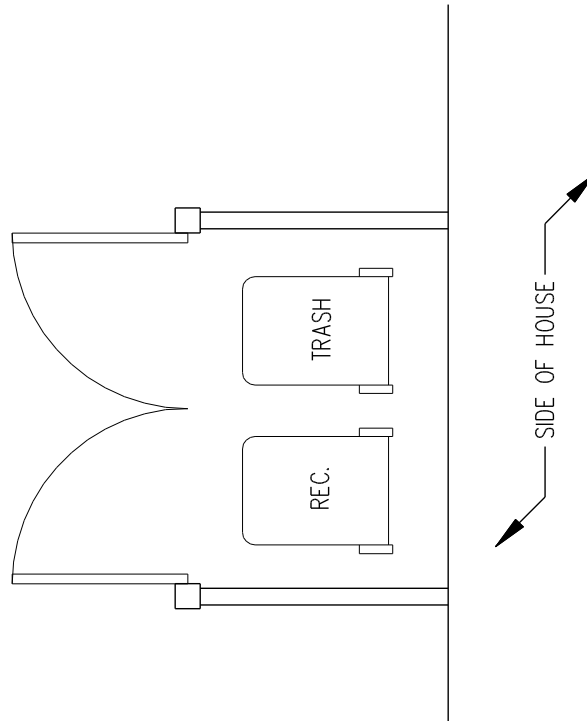

**FIBER CEMENT ENCLOSURE  
(STREET ELEVATION)**

For questions regarding the restrictions in Woodcreek Farms, please contact the HOA Association Manager.



## **Landscape and Hardscape Guidelines**

Any alteration or addition to the exterior of any property, grounds, landscaping, hardscaping, building, out building, fence, wall, or structure of any kind in Woodcreek Farms requires the submission of a Request for Architectural Review.

A Request for Architectural Review form is available from the Woodcreek Farms HOA.

### **Incomplete submissions will not be accepted.**

**Mail or drop off completed forms to:** Architectural Control Committee (ACC) c/o Woodcreek Farms HOA at the Association office. The ACC may require additional information to be submitted as it deems necessary. The ACC will respond within 30 days of a complete submittal. All approvals shall be in writing. Please contact the Woodcreek Farms HOA with any questions. ACC approvals for landscaping are valid for a period of six months. Owner is responsible for contacting ACC if project is expected to extend longer than this period.

### **Checklist for Request for Architectural Review**

1. **Review Fee:** A check payable to Woodcreek Farms HOA must accompany the application for design review. Refer to the "Request for Architectural Review" – Exhibit "A".
2. **Request for Architectural Review**
3. **Copy of Plat:**
  - Submit a plat with location of the modifications clearly marked. Plats need to be drawn to scale and show the lot size, boundary locations, nearby streets, flood zones, and any easements, setbacks or rights of ways.
4. **Minor Modifications:**
  - Description of modification, plus any additional information such as samples, manufacturer name, proposed color, product information or specifications, brochures, and photographs. *Plans drawn to scale are preferred but not required.*
5. **Major Modifications or New Home Construction:**
  - Site plan to scale (1:10 or 1:20) is required.
  - Site plans shall show boundary lines of lot, setbacks, easements, footprint of house, porches, decks, accessory structures, driveways, walks, patios, walls, and fences. Front, side, and rear setbacks shall be identified.
  - All "no-clear" and natural buffer areas shall be clearly shown.
  - Site Drainage patterns shall be clearly shown.
  - A tree survey showing the location of any tree considered a "grand tree" as defined by the City of Columbia Landscape ordinance.
  - Indicate exterior light location and type, location of HVAC units, and trash enclosures, pools, fences, spas, garage doors, and other recreational equipment.
  - Please provided architectural house plans (floorplans and elevations, as applicable).

For questions regarding the restrictions in Woodcreek Farms, please contact the HOA Association Manager.



***To facilitate approval, the Landscape or Hardscaping Plan should meet or exceed the following general guidelines and requirements:***

### **Guiding Principles**

Appropriate landscaping is a critical component of the overall look and feel of Woodcreek Farms. One should approach the landscaping of a residential lot with an attitude like that demonstrated in the placement, design and detailing of the house. Variables to consider while developing the landscape design include the type, location, size, and configuration of the lot; the design and configuration of the house; site drainage; solar orientation; street trees; existing vegetation; and adjacent residential lots.

Landscape designs should be ordered and well composed, rather than random and scattered. Trees, shrubs, hedges, and ground cover should be massed together in appropriate groupings to make and frame outdoor living spaces and garden rooms, to reinforce the major entry, define the relationship/transition between public and private areas, and to enhance the design of the house, the street and the neighborhood. Emphasis should be placed on the creation of space, rather than filling voids in the lot.

### **Landscaping Requirements**

1. A basic landscaping plan shall be designed by a Landscape Architect or person of similar competence and experience and shall be submitted for approval by the ACC.
2. Trees and natural areas or no clear areas left in good condition on a site will be considered in the approval process and will lessen the requirement for planted material.
3. Landscape installation shall be completed according to approved plans prior to occupancy of the home.
4. Plan shall include a Plant Schedule clearly stating and locating plant name, (genus, species, and common name to include cultivar or variety), quantity and size. Plants specified by container shall also specify the height and spread meeting or exceeding the American Nursery Stock Standard.
5. Plants should be located on the plan with an easily understood key.
6. Each yard shall contain appropriate foundation plant material, sized in proportion with the scale of the house and lot. The ultimate size of plants indicated needs to be taken into consideration. The goal is to highlight, not hide the home. Native species are strongly encouraged.
7. Requirements for the measurements, branching, grading, quality, balling and burlapping of plants in the Landscape Plan shall follow or exceed the code of standards currently recommended by the American Association of Nurserymen, Inc. in the American Standard for Nursery Stocks. In some cases, the ACC may impose more restrictive requirements.

For questions regarding the restrictions in Woodcreek Farms, please contact the HOA Association Manager.



8. Proper plant size and placement will be required, and Landscape Plans shall follow generally accepted practices of the landscape design industry. House corners, significant angles and stairs should be accented with evergreen foundation material. In general, each landscape should serve to soften the view of the home from the street vantage, and positively add to the aesthetics of the neighborhood and blend cohesively with the general neighborhood greenscape.
9. Each Landowner shall plant at least three (3) large maturing shade or canopy trees in the front yard area 3" Caliper Minimum, with written exceptions granted on smaller or heavily wooded lots. Additional flowering species such as dogwoods, cherries, plums, crabapples and crape myrtles will also be considered. Where a crape myrtle, birch or other multi-stem species are to be used as a front accent plant, field grown or field-to-pot specimens will be required in order to achieve suitable caliper.
10. Screening planting of Garage Doors and turn-arounds, HVAC units, irrigation wells/covers, trash enclosures, pools, spas, and other recreational equipment is required. Screen planting should be a minimum 4' high at time of planting unless otherwise permitted by the ACC.
11. All grass used in landscape plan shall be sod. All areas of property must be landscaped; either sodded, planted and mulched with no excessive areas of mulch left unplanted.
12. Mulch shall be of natural material pine straw or wood bark/chips (pine or hardwood) (no gravel, white rock, or unnatural dyed mulch (i.e. red).
13. Rocks in the landscape shall be used sparingly. No more than 10% of a landscape bed shall be covered with rock. All rocks used shall be either gray or brown in color. No white rocks shall be permitted. Rocks are allowed as accents in plant beds and for use in drainage swales but should not cover landscape beds in their entirety.
14. The owner may elect to install landscaping edging. Front yard edging shall be limited to brick, decorative concrete edging, stone block of a natural color, or steel appropriately installed. Colored and stamped concrete hardscapes may be used as accents on the back of homes and around pool areas, but should not be used on the street view of a house. Plastic edging is not permitted.
15. No artificial or synthetic turf is permissible in the public realm or where it is visible from a neighboring property.
16. A twenty-five foot (25') natural buffer area shall exist along the entire width of any lot adjacent to a major road or golf course area. Clearing of dead and decaying trees is allowed in these areas, but the impact in these areas should be minimal. The ACC must specifically approve any clearing, removal, pruning or thinning of plant and tree species in this buffer area. To avoid fines, or mitigation requirements please contact the ACC for questions or clarifications before removing material from the natural buffer area.
17. Additional landscape accents such as fountains or garden ornaments shall be considered on a case-by-case basis, but in any event shall not exceed 72". In most cases these shall only be permitted in private areas unseen from the public view.
18. Fencing, swimming pools, and additional landscape items will be reviewed and approved on a case-by-case basis. Please see the Woodcreek Farms Architectural Guidelines for fence detail.
19. Proper maintenance and timely replacement of dead or dying plant material is expected and required.
20. All landscaping is required to be mechanically irrigated.

For questions regarding the restrictions in Woodcreek Farms, please contact the HOA Association Manager.



21. Where a lot abuts a pond, stream or lake area, a natural shoreline area of existing, undisturbed vegetation no less than thirty feet (30') in depth should be maintained during the entire construction process. In addition, silt fences should be utilized as necessary and by law. Landowners must make all reasonable efforts to maintain the integrity and health of water areas. The ACC maintains the right to require landowners to undertake further reasonable mitigation, erosion control or other lake or streamside management activities on a case by case basis. After construction, a ten-foot (10') natural area (an undisturbed ecological zone) shall be left along the entire length of the property adjacent to water areas. Boat docks are not permitted. The purpose of these guidelines is to minimize the impact on surrounding ecological zones. Buffer areas create a filtration zone for runoff and landscape chemicals, provide habitat and offer a natural screen for surrounding homes. Please help us maintain the integrity of our water areas and native plant colonies. The ACC is available for questions and assistance with all related areas.
22. If the Landowner does not comply with the Landscape Plan as approved by the ACC, the ACC will provide notice in writing or by e-mail of such non-compliance to the Landowner and a reasonable time for the Landowner to cure any non-compliance. If the Landowner fails to cure the non-compliance after such notice and time to cure, the ACC shall provide a second notice of non-compliance and maintains the right to levy fines, place a lien on the Landowner's property, or pursue other legal remedies to ensure proper compliance.
23. Any amendments, alterations, variations or significant additions to the Landscape Plan ("Amendments") must be approved in writing by the ACC. Initially, the Landowner is not required to provide a new, formal Landscape Plan for amendments. The Landowner should provide the ACC with a brief description of the Amendments and await approval. The ACC will make every effort to expedite approval of Amendments within thirty (30) days of notice or submittal. In its sole discretion, however, the ACC may require formal, detailed plans to be submitted regarding Amendments. Under no circumstances shall work commence without prior written approval from the ACC.
24. Invasive species as defined by Clemson University Extension Service will not be permitted.
25. The ACC may in certain instances of tree removal, require replacement of 2-3 trees. The ACC, in its sole discretion, may require that such trees be relocated or replaced. Stumps of removed trees shall be ground and removed.
26. The ACC may require a written statement of a certified arborist to verify trees requested for removal are diseased or dying.
27. All undisturbed natural wetland buffer areas shall be maintained per Richland County Land Development Ordinances.
28. All proposed hardscapes shown on landscaping plans shall identify the material to be used for approval prior to construction. This includes, but not limited to, driveways, sidewalks, patios, pool decks, etc.  
The ACC and Board of Directors reserve the right to periodically update the landscape guidelines and requirements without notice.

For questions regarding the restrictions in Woodcreek Farms, please contact the HOA Association Manager.



## Pre-Approved Plant List

The following is a pre-approved plant list and not an exhaustive plant list. Other plants and varieties can be used if approved.

### Shade Trees

Red Maple  
River Birch  
Ginkgo  
Tulip Poplar  
Chinese Pistache Sycamore  
Nuttall Oak  
Overcup Oak  
Willow Oak  
Sawtooth Oak  
Shumard Oak  
Live Oak  
Chinese Elm  
Redwood  
Black Gum  
Bald Cypress

### Evergreen Trees

Loquat  
Hollies  
Nellie R. Stevens  
Foster  
Savannah  
Emily Bruner  
Other Hollies  
Eastern Red Cedar  
Pine  
Palmetto  
Tree Form Yaupon  
Sweetbay Magnolia  
Tree-Form Hollies  
Arborvitae  
Deodar Cedar  
Cryptomeria  
Magnolia  
Palmetto  
Wax Myrtle

### Flowering Trees

Trident Maple  
Japanese Maple  
Service Berry  
Crab Apple  
Eastern Redbud  
Flowering Dogwood  
Crape Myrtle  
Little Gem Magnolia  
Saucer Magnolia  
Sweet Bay Magnolia  
Cherry  
Vitex

### Groundcovers (pint minimum)

Vinca Major  
Carolina Jessamine  
Ivy  
Cast Iron  
Climbing Fig  
Daylily  
Lantana  
Liriope  
Mondo Grass  
Asiatic Jasmine  
Confederate Jasmine

For questions regarding the restrictions in Woodcreek Farms, please contact the HOA Association Manager.



**Shrubs/Grasses**

- |                      |                 |
|----------------------|-----------------|
| Abelia               | Shore Juniper   |
| Azalea               | Kerria          |
| Barberry             | Loropetalum     |
| Boxwood              | Banana Shrub    |
| Sweetshrub           | Maiden Grass    |
| Camellia             | Switch Grass    |
| Yew                  | Nandina         |
| Deutzia              | Tea Olive       |
| Fatsia               | Pittosporum     |
| Guava                | Indian Hawthorn |
| Forsythia            | Rosemary        |
| Gardenia             | Spirea          |
| Hydrangea            | Viburnum        |
| Burford Holly        | Yucca           |
| Carissa Holly        | Gardenia        |
| Inkberry Holly       | Burning Bush    |
| Japanese Holly       | Sasanqua        |
| Dwarf Yaupon Holly   | Cleyera         |
| Other Hollies        | Anise           |
| Primrose Jasmine     | Muhly grass     |
| Dwarf Sabal Palmetto | Lomandra        |
| Sargent Juniper      |                 |
| Parsons Juniper      |                 |

**NOTE: All plant material shall conform to American Nursery Stock Standard Z-60.1**

For questions regarding the restrictions in Woodcreek Farms, please contact the HOA Association Manager.





## **Clubridge B-5, Courtyard Villas, and Northwoods Villas Pre-Approved Plant List and Design Consideration**

### **Plant A (Accent Plant - Plant Shall Be A Minimum Of 30" Ht. At Installation)**

- Buxus Microphylla 'Wintergreen' - Japanese Boxwood
- Camellia Sasanqua 'Shishi Gashira' - Dwarf Camellia
- Thuja Occidentalis 'Congabe' - Dwarf Arborvitae

### **Plant B (< 18" Ht. At Maturity - Plant Shall Be A Minimum Of 12" Ht. At Installation)**

- Hemerocallis 'Stella De Oro' - Yellow Day Lily
- Drift Rose Species
- Agapanthus 'Brilliant Blue' PP25966 - Agapanthus
- Cephalotaxus Harringtonia 'Prostrata' – Dwarf Cephalotaxus
- Dianella Tasmanica 'Variegata' – Variegated Flax Lilly

### **Plant C (< 36" Ht. At Maturity - Plant Shall Be A Minimum Of 24" Ht. At Installation)**

- Rhododendron - Dwarf Encore Azalea (No Larger Than 3' Ht)
- Distylium 'Piidist-V' - Cinnamon Girl Distylium
- Abelia X 'Rose Creek' - Rose Creek Abelia
- Buxus Microphylla 'Wintergreen' - Wintergreen Boxwood
- Ilex Vomitoria 'Nana' - Dwarf Yaupon

### **Plant D (24 - 36" Ht. At Maturity - Plant Shall Be A Minimum Of 24" Ht. At Installation)**

- Hydrangea Paniculata 'Little Lime' - Little Lime Hydrangea
- Miscanthus Sinensis 'Adagio' - Adagio Grass
- Lomandra Longifolia 'Lm200' PP - Dwarf Mat Rush
- Loropetalum Chinense 'Kurobijin' PP 23,176 – Cerise Charm Loropetalum
- Dwarf Buddleia – Dwarf Butterfly Bush

### **Plant E (8-10'ht At Maturity - Plant Shall Be A Minimum Of 6-8' Height At Installation)**

- Osmanthus Fragrans - Sweet Tea Olive
- Camellia Sasanqua Species
- Ilex X 'Mary Nell' - Mary Nell Holly
- Ilex X 'Emily Bruner' - Emily Burner Holly
- Cleypora Japonica – Cleypora

For questions regarding the restrictions in Woodcreek Farms, please contact the HOA Association Manager.

**Plant F (Small Ornamental Tree - Plant Shall Be A Minimum Of 12' Height At Installation)**

- Multi Trunk - Crape Myrtle Species
- Acer Buergerianum - Trident Maple
- Acer Palmatum 'Bloodgood' - Bloodgood Japanese Maple
- Prunus X Yedoensis – Yoshino Cherry
- Vitex Agnus-Castus - Vitex
- Pistacia Chinensis, The Chinese Pistache

**Clubridge B-5, Courtyard Villas, and Northwoods Villas Plant Design Layout Example**

---

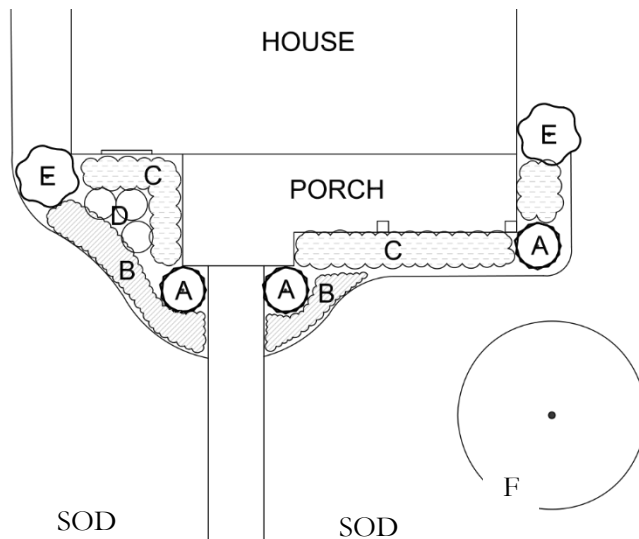

**NOTES:**

- 1) All plants shall meet the standards and specifications of The American standard for nursery stock, latest edition.
- 2) This is a pre-approved list and not meant to be exhaustive.

For questions regarding the restrictions in Woodcreek Farms, please contact the HOA Association Manager.



## **Fee Schedule**

There are fees associated with the various types of plan review in Woodcreek Farms. These fees are due upon submittal of plans. Plans will not be accepted without a check for the appropriate review fee. Fees are non-refundable once the application has been submitted. Refer to "Request for Architectural Review" – Exhibit "A" for fee information.

For questions regarding the restrictions in Woodcreek Farms, please contact the HOA Association Manager.